

Air Blow Unit (AB2-**) Instruction Manual

Please read this instruction manual carefully
before operating this unit and use our product correctly.
After reading this instruction manual, be sure to keep it in a place where a person
who uses or manages the equipment can check it at any time.

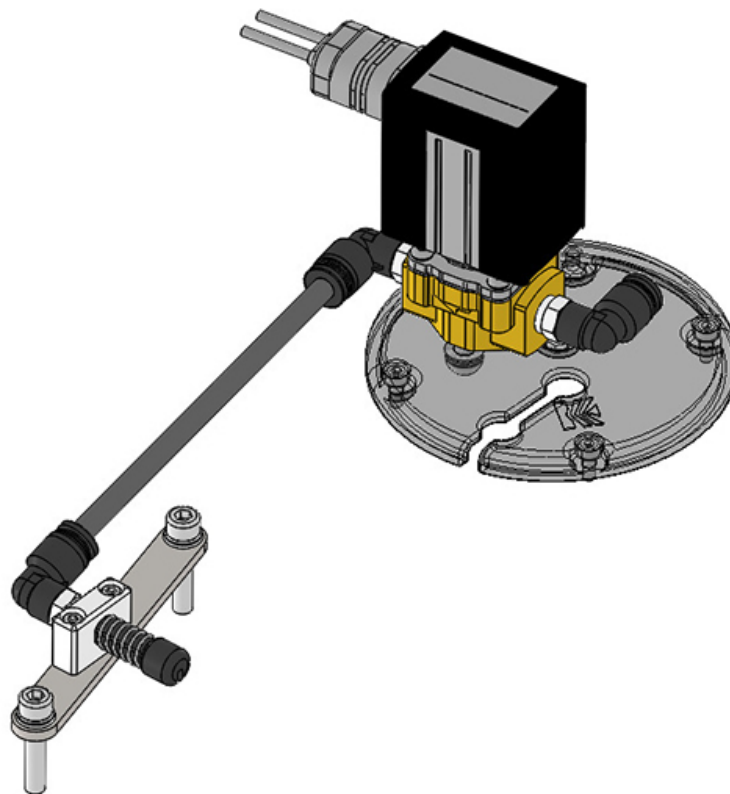

TABLE OF CONTENTS

1. Safety Precautions	_____	2
2. Parts List	_____	3
3. Assembly Procedure	_____	4
4. Maintenance	_____	8
5. Order Model	_____	8
Contact	_____	9

1. Safety Precautions





■ Introduction

The Air Blow Unit (AB2) is a tool for our Dressers to prevent chips being stuck while dressing cap tips.

This is a product exclusively for preventing chips being stuck. Do not use for any other purpose. Do not use for Changers other than the specified models.

We do not assume any responsibility for malfunctions, repairs, accidents, or others which occurred by using with un-specified models or by other purpose.

■ Regarding Signs

 Warning	It indicates contents informing possibilities of death or serious injury in case of incorrect handling.
 Caution	It indicates contents informing possibilities of injury due to handling error or occurrence of material damages.
	This symbol indicates operations that should not be done.
	This symbol indicates operation that should be done.

2. Parts List

■ Example for CDK-R

No.	Name	Model	QTY	Note
1	Air Blow Nozzle Holder Block	AB2-BLOW-BL-03-001	1	
2	Air Blow Nozzle	AB2-BLOW-NZ-01-003-S	1	
3	Air Blow Bracket for K-Model	AB2-BLOW-K-BR-01-001	1	For CDK-R
4	Samini Compressed Spring	12-1021	1	
5	CKD Solenoid Valve	FFB-3106A3C3A3	1	
6	PISCO Fitting	PL6-01	2	
7	PISCO Fitting	PL6-M5	1	Tighten with ②. Tightening torque :1.5N/m
8	PISCO Spatter Tube (φ6)	FB0640	1	170mm

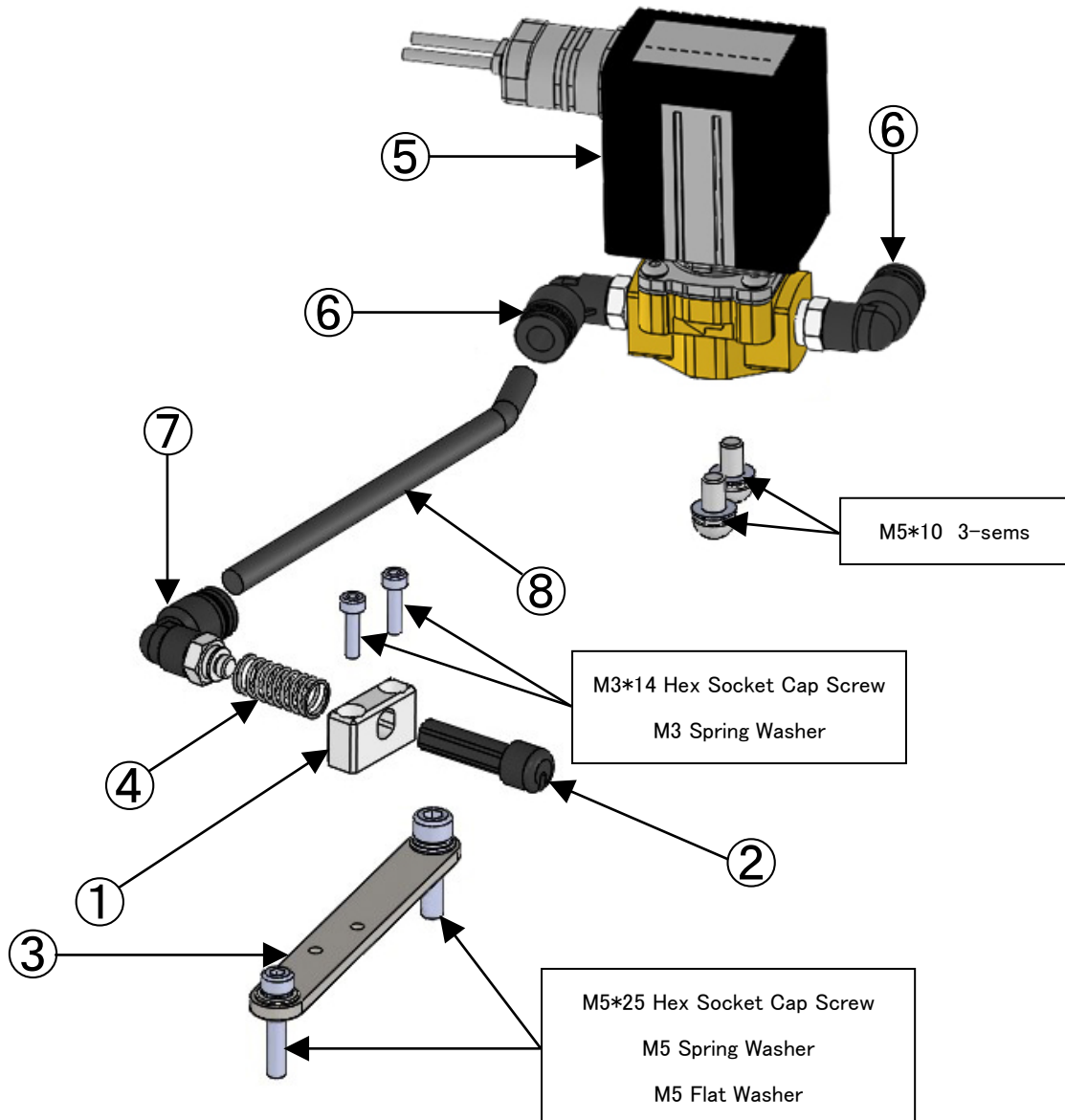

3. Assembly Procedure

*Image below is an example of installing to CDK-R.

■Precautions

1. Make sure that the air flow is following the arrow direction.

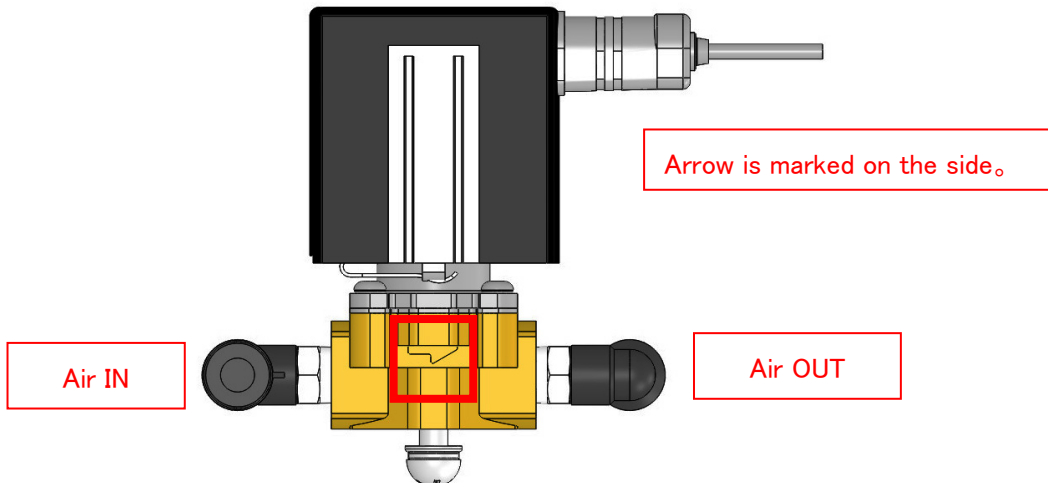

2. Check the air pressure. (range: 0.3 ~ 0.5 MPa)
3. Some parts are made of Synthetic Resin. Excessive screw tightening may damage the product.

■ Procedure

1. Remove the screws from the Dresser, then attach the bracket with screws enclosed.

(M5*25 Hex Socket Cap Screw, M5 Spring Washer, M5 Flat Washer is used.
Tightening torque 4.5N/m)

*This product is available to both left and right side by flipping the bracket. Be careful of the orientation when attaching.

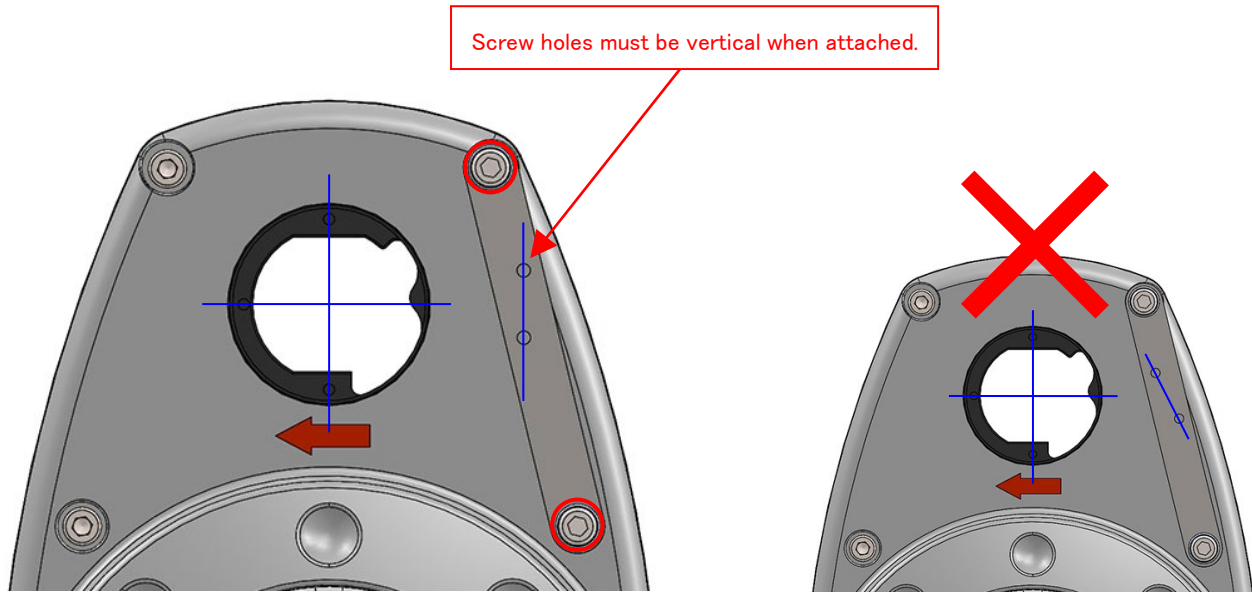

2. Attach Nozzle ASSY to the bracket. (Use M3*14 Hex Socket Cap Screw, M3 Spring Washer. Tightening torque 1.0N/m)

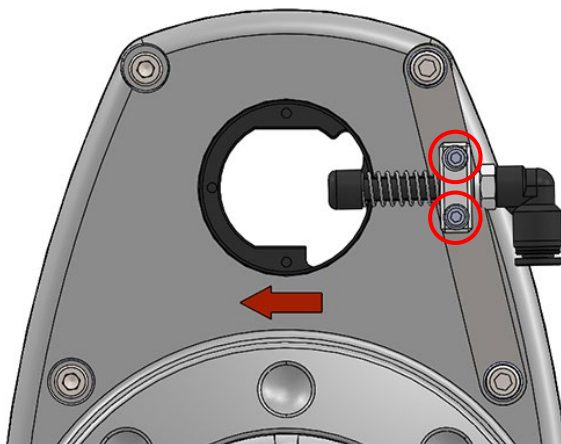

3. Attach the Solenoid Valve.
(Use M5*10 M5*10 3-sems. Tightening torque 4.5N/m)

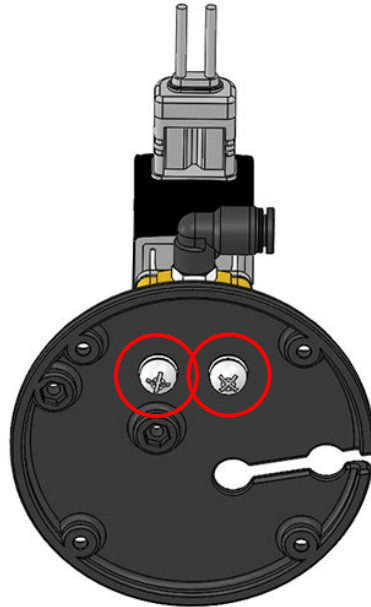

4. Attach the Spatter Tube.

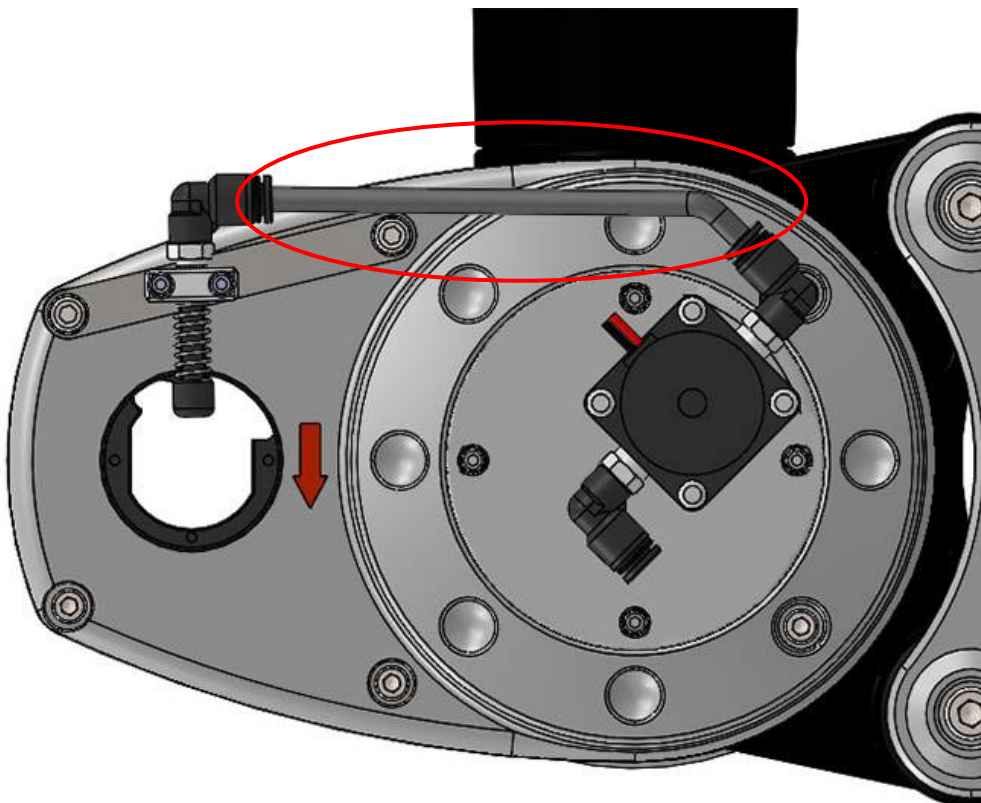

5. Completion

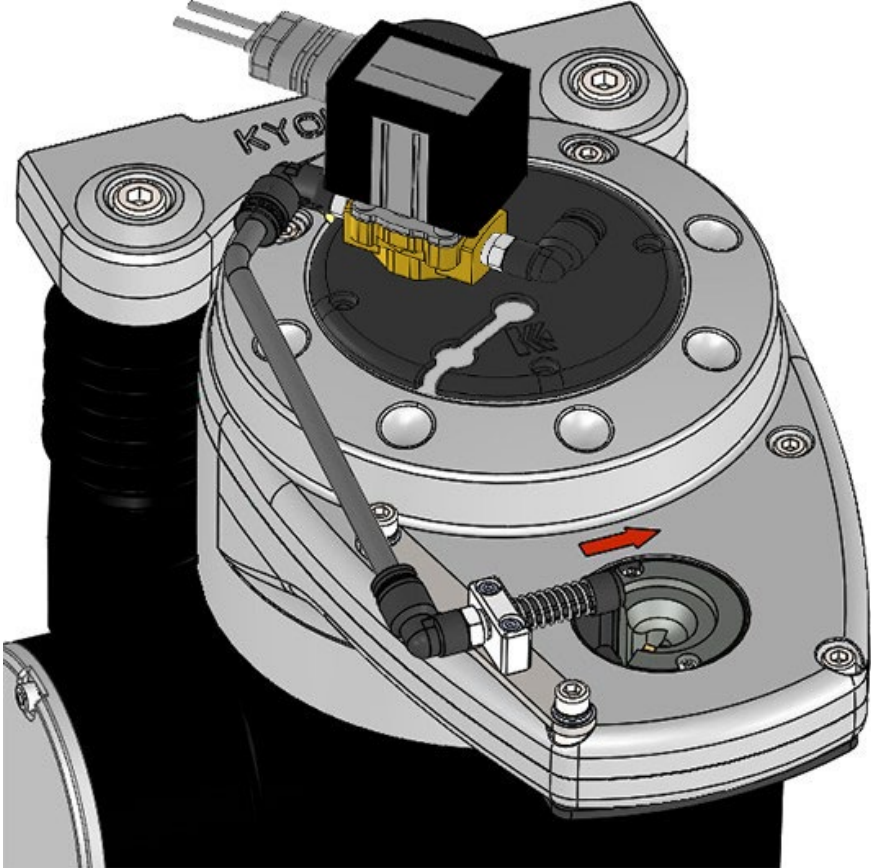

4. Maintenance

Changing Cutter / Holder can be done without removing the Air Blow Unit. Squeeze the Nozzle when changing the Cutter / Holder as the image below.

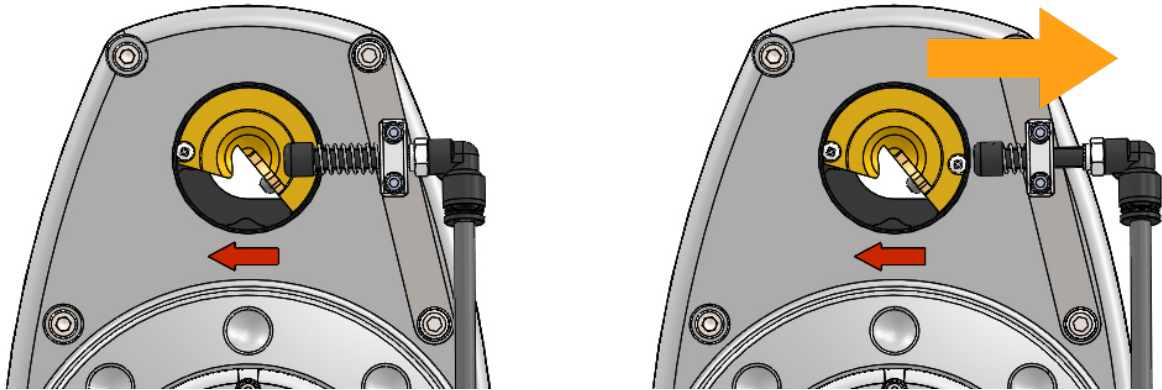

5. Order Model

Model	Correspond Dresser	Note
AB2-K	CDK-R	
AB2-KSG	CDK-SG	
AB2-BA	CDK-BAYO	
AB2-SV	CD-SVR	

*Special parts may be required according to position of dresser or gun motion. Please call us for more information.

Contact

Contact us if there is any damage or machine defects in our products.



KYOKUTOH CO., LTD.

181-1, Nakayashiki, Orido-cho, Nisshin, Aichi 470-0115 Japan

TEL +81-561-72-8811 FAX +81-561-72-8821

E-Mail: sales@kyokutoh.com

<http://www.kyokutoh.com>

KANTO SALES OFFICE

TEL +81-49-277-4324 FAX +81-49-277-4325

HIROSHIMA SALES OFFICE

TEL +81-82-569-6227 FAX +81-82-569-6228

FUKUOKA SALES OFFICE

TEL +81-92-410-6977 FAX +81-92-410-6988



CHANGER & DRESSER CORPORATION

1527 ITC Way, Anniston, AL 36207 U.S.A

TEL +1-256-832-4392 FAX +1-256-832-4393

<http://www.changer-dresser.com>



KYOKUTOH CHINA

73 Huagang Street, Xiuquan Town, Huadu District,

GuangZhou City, GuangDong Province, China.

TEL +86-20-86980880 FAX +86-20-86980890

<http://www.kyokutoh.com.cn>



KYOKUTOH THAILAND

339/2 Soi Phattanakarn 69, Phattanakarn Road, Prawet,

Bangkok 10250 THAILAND

TEL +66-272-162-82 FAX +66-272-162-84

<http://www.kyokutoh.co.th>

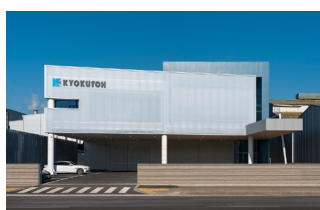

KYOKUTOH KOREA

38-6 , Wonsi-dong (Byeolmang-ro 511) ,

Danwon-gu, Gyeonggi-do, KOREA 15600

TEL +82-31-414-8730 FAX +82-31-414-8731



KYOKUTOH EUROPE

Max-Planck-Str.4 59423 Unna Germany

TEL +49-2303-93-615-00 FAX +49-2303-93-615-29

<http://www.kyokutoh.de>

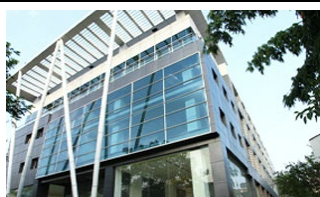

KYOKUTOH WELD INDIA

Office No.19, 3rd Floor, Aditya Centeegra, FC Road, Deccan,

Pune - 411004

TEL +91-20-68297011 FAX +91-20-68297011