

CVC5 Chip Collector (CVC5-**2 series) Instruction Manual

Please read this instruction manual carefully
before operating this unit and use our product correctly.
After reading this instruction manual, be sure to keep it in a place where a person
who uses or manages the equipment can check it at any time.

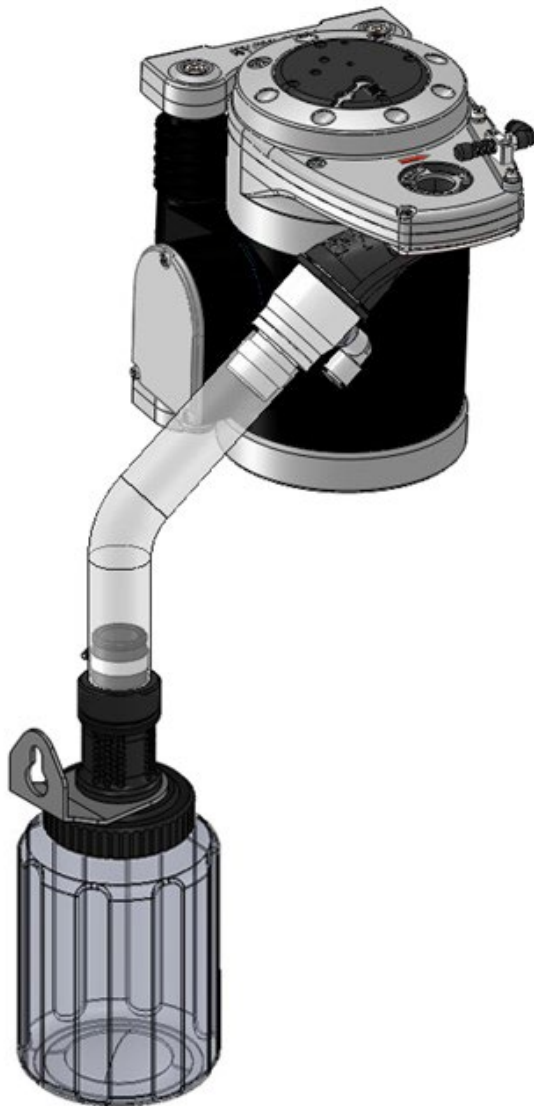

TABLE OF CONTENTS





1. Safety Precautions	_____	2
2. External Dimension Diagram	_____	3
3. Parts List (Chip Collector)	_____	4
4. Parts List (Dust Box)	_____	5
5. Assembly Procedure	_____	6
6. Cautions and Confirmation before the Operation	_____	10
7. How to Dispose of Chips	_____	11
8. Timing Chart	_____	12
9. Maintenance	_____	13
10. Troubleshooting	_____	15
11. Supplement	_____	15
Contact	_____	16

1. Safety Precautions

■Introduction

When used with a dresser manufactured by KYOKUTOH, this chip collector will efficiently collect the chips that are generated during dresser operation. It cannot be attached to any dressers other than the specified models. Please do not use for any purpose other than described in this manual. We are not be able to take a responsibility for any damage or injury caused by results other than specified in this manual.

■Regarding Signs

 Warning	It indicates contents informing possibilities of death or serious injury in case of incorrect handling.
 Caution	It indicates contents informing possibilities of injury due to handling error or occurrence of material damages.
	This symbol indicates operations that should not be done.
	This symbol indicates operation that should be done.



■Recommended Air Pressure

Pneumatic pressure in the range of 0.45 to 0.55 MPa to use. Use beyond the range may cause malfunction.

■Recommended Facility

Check the usage environment before the installation. Supply oil-free compressed air by using an oil mist separator or etc. If the air contains oil, dressed chips may not be swallowed properly.

■Before Installing

	Do not use pipes with different diameters or other fittings (ex. Replacing with speed controller). The performance may decrease if different parts are used.
	Check the pipe diameter of input side. The product is designed to use $\phi 10$ hose (outer diameter).

2. External Dimension Diagram

■ for CDK-R

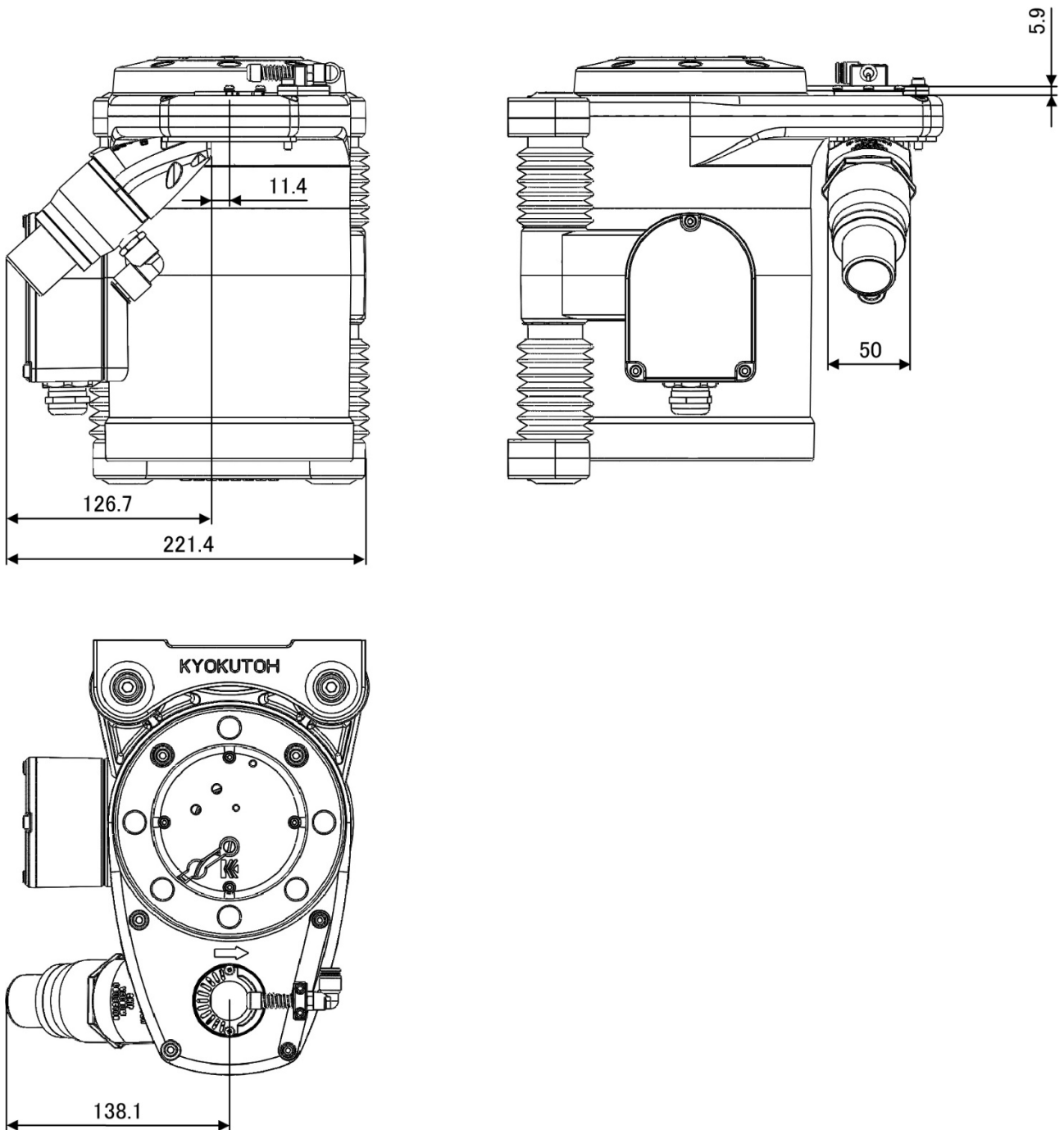

3. Part List (Chip Collector)

■ for CDK-R

No.	Name	Model	QTY	Note
1	CVC5 chip collector	CVC5-BODY-PO-001-SET	1	
2	Adapter for K type	CVC5-K-ADPT-01-001-SET	1	
3	Holder cover	TCCR-JF03-KHL-SET	1	
4	Vacuum assembly	CD-VAC2-SPN	1	
5	AB2 set	AB2	1	※Option
6	AB2 adopter for K type	AB2-K-ADW-SET	1	※Option
7	AB2 hose set for K type	AB2-KSG-HOSE-SET	1	※Option

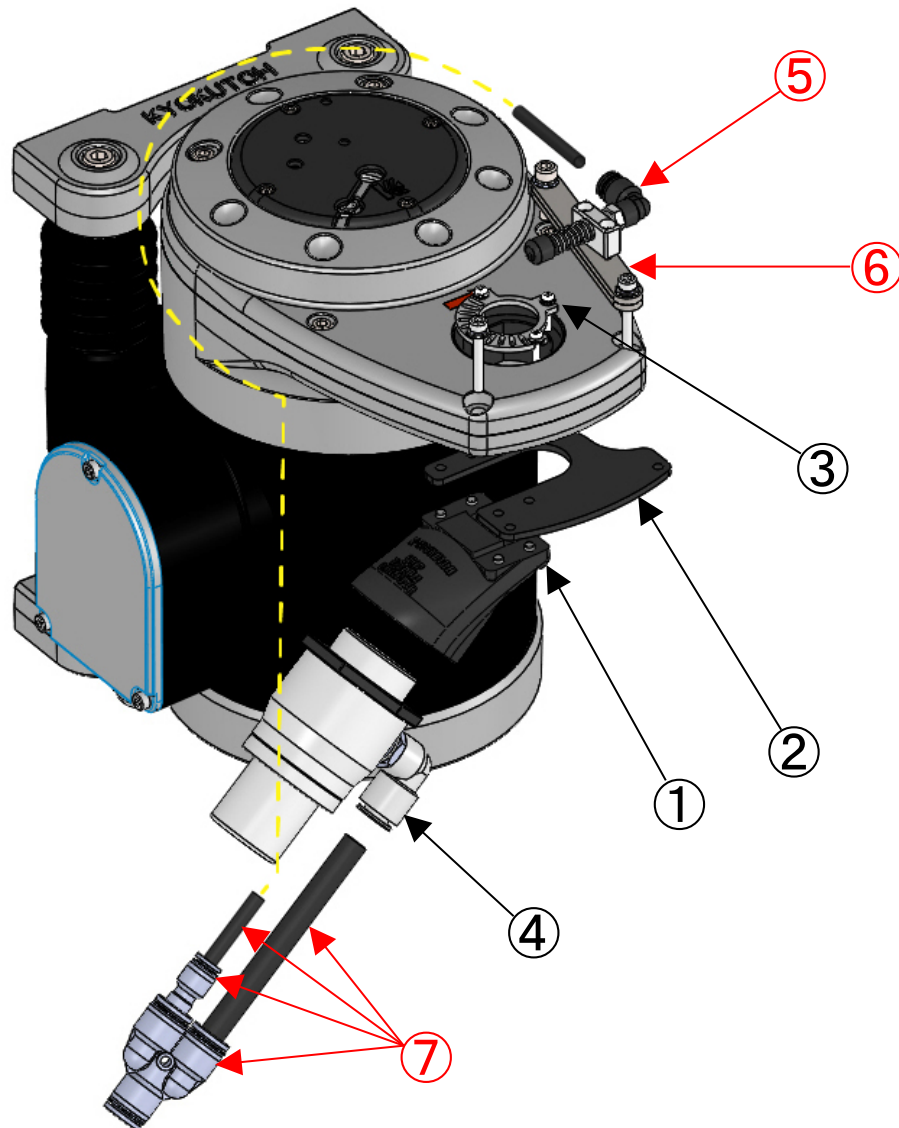

4. Parts List (Dust Box)

No.	Name	Model	QTY
1	Hose band	40	2
2	Hose (1m)	φ32 (inner dia.)	1
3	CVC DB upper cover	DB-01-WODB-SET	1
4	PET dust box	PET-DB-180-01-001	1

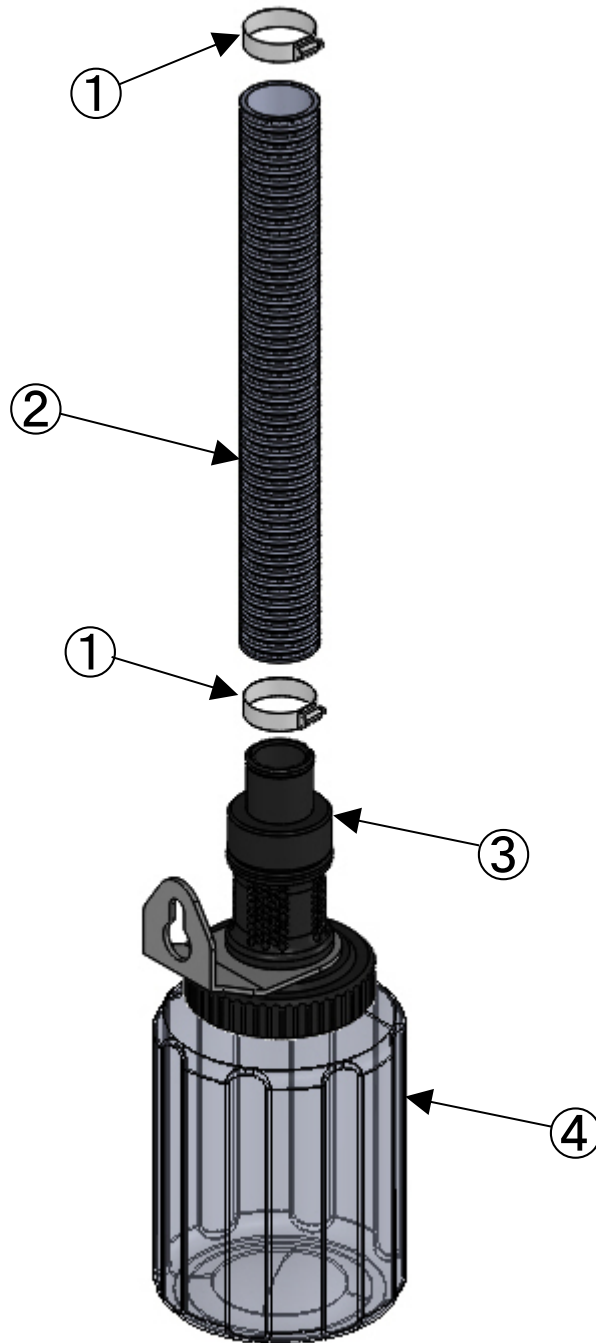

5. Assembly Procedure

※For CDK-R.

■Procedure

1. Remove the bolt (M5-16L x 2pcs) referring to the figure below.

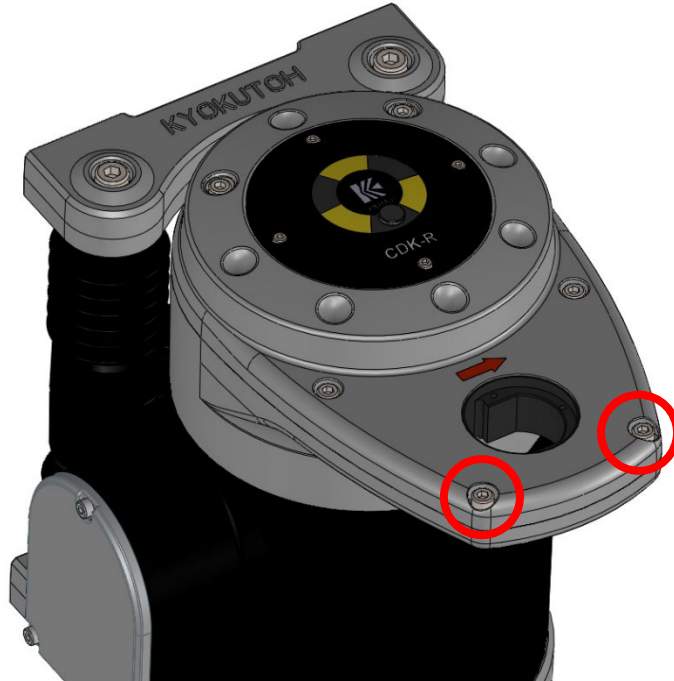

2. Mount an adopter with accessory cap bolts and Washer (M4-30L x 2pcs and M4).

※When installing the air blow unit, use the bolt attached to the air blow unit accessory. For details, refer to the air blow unit manual.

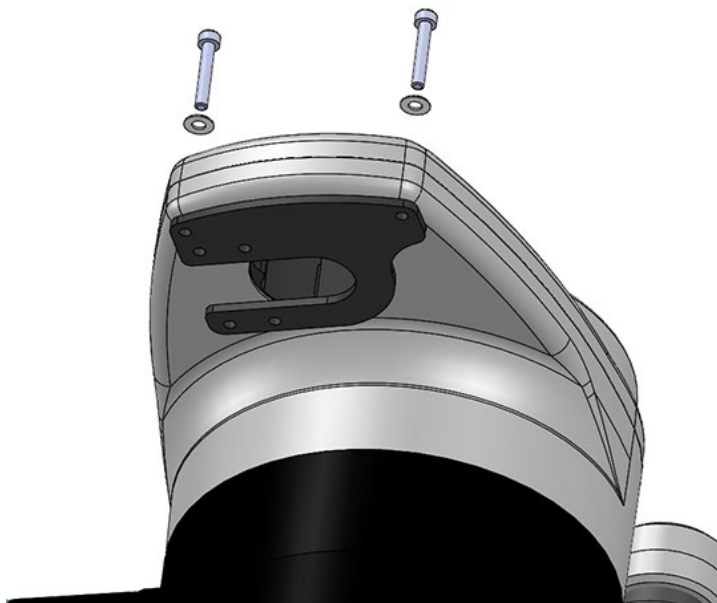

3. Mount a chip collector with 3-point sems bolt (M4-8L x 4pcs) on the adopter.

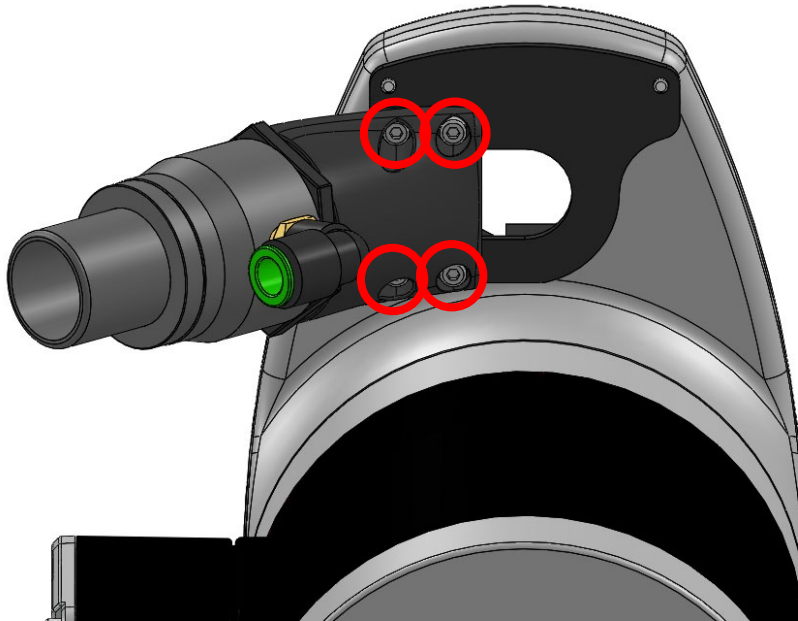

4. Attach hose and hose band to chip collector.
※For the hose, a standard 1 (m) hose comes included. Cut it before use if it is too long.

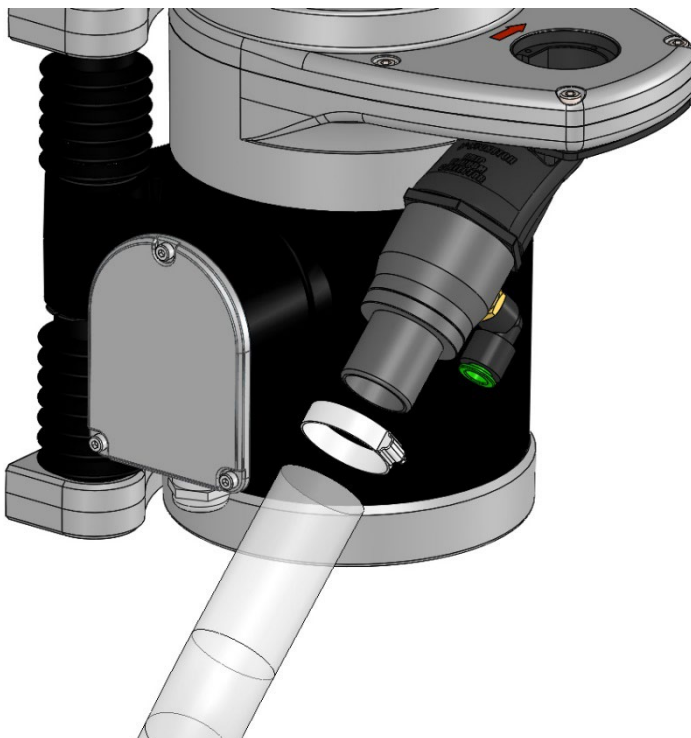

5. Attach the dust box, hose and hose band.

※For the hose, a standard 1 (m) hose comes included. Cut it before use if it is too long.

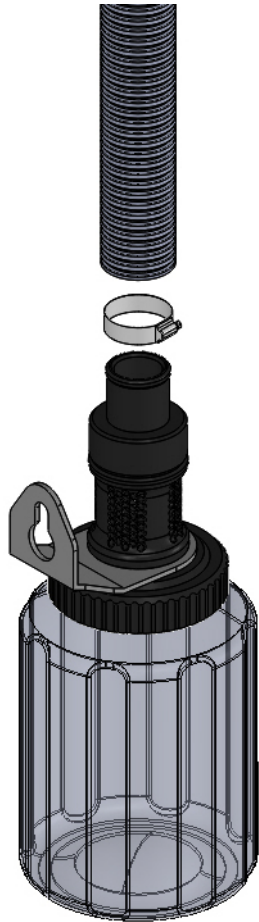

6. Attach the holder cover.

※For the hose, a standard 1 (m) hose comes included. Cut it before use if it is too long.

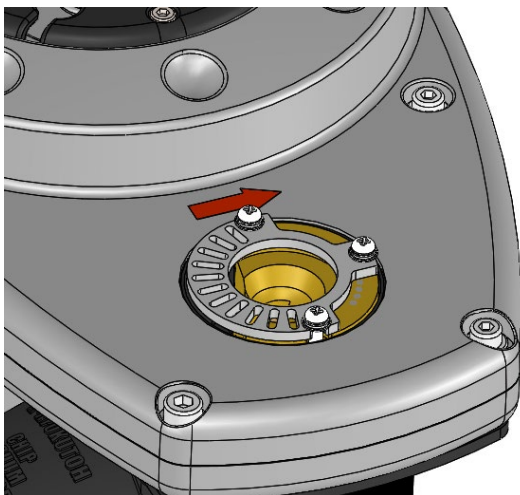

7. Attach the sir hose.

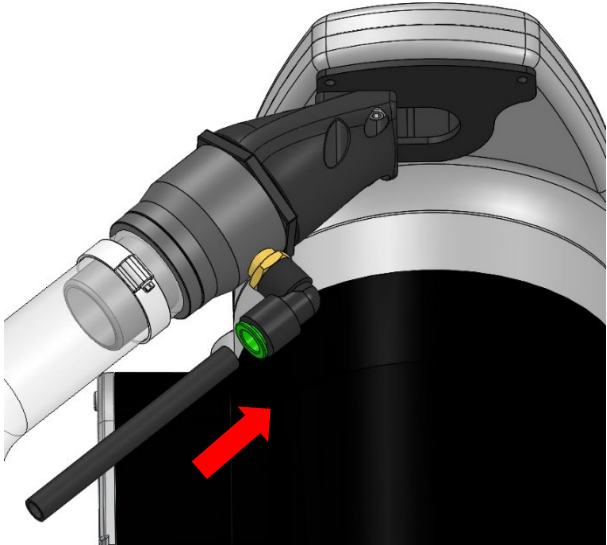

8. Completion



6. Cautions and Confirmation before the Operation

■Notes

1. Use an air hose with an outer diameter $\varnothing 10$ for vacuum unit.
2. Pneumatic pressure in the range of 0.45 to 0.55 MPa to use.
Use beyond the range may cause malfunction.
3. For the hose, a standard 1-m hose comes included. Cut it before use if it is too long.
4. If you use the hose with it bent at an acute angle, it may cause chip clogging or hose damage, so please use it with an appropriate bend angle (100R or more).
5. Although flame-retardant materials have been used for the hose, it will not be able to withstand extreme heat.
6. If you use the hose with a length of more than 1 m, the product may not be able to demonstrate its proper performance due to lowering the suction force.
7. Tightening the screws with strong force may cause damage.

Check the above notes before starting the operation.

7. How to Dispose of Chips

■Notes

Discharge the dust in dust box DB-01 before chips clog it up completely. The chip size will vary depending on the product or the use conditions, but for a general dress setting at $\phi 16$ (polishing at 1500 N/sec), DB-01 will be full of chips after dressing about 1500 times (for 1500 seconds).

If you use the machine with chips still built up in DB-01 without having been discharged, it will cause poor suction.

■Procedure

- 1) Remove the dust box.

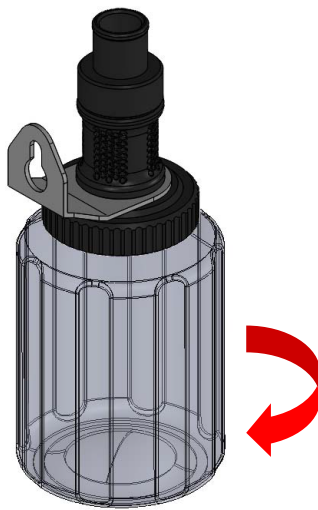

- 2) Dispose of the chips and assemble the dust box.

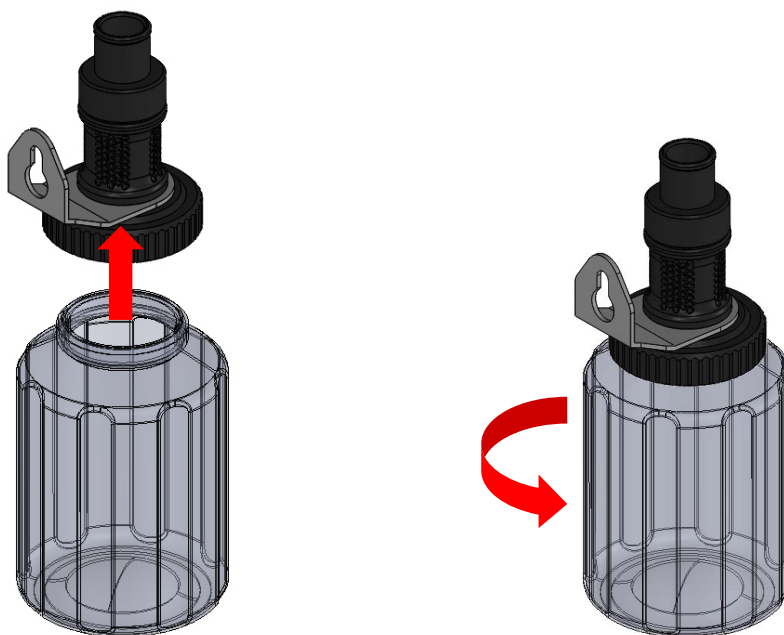

8. Timing Chart

■CVC air timing chart example

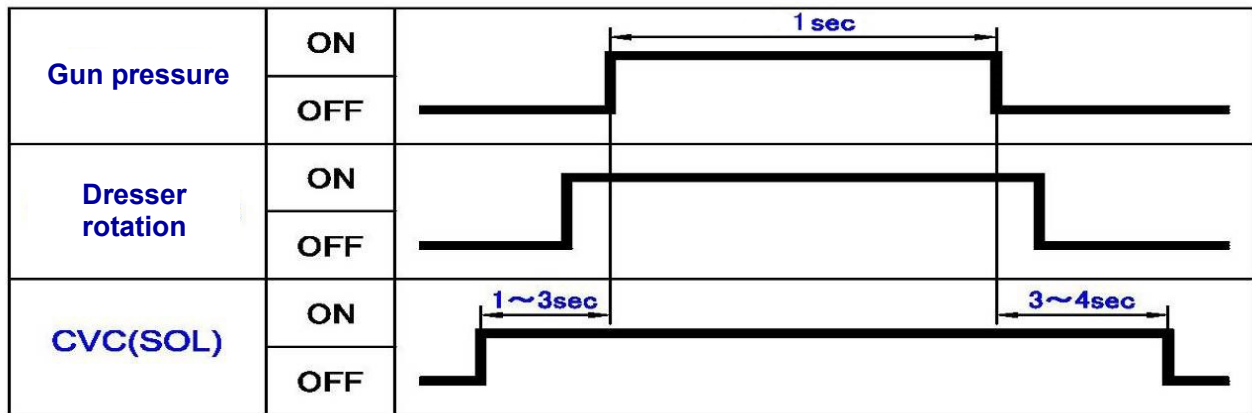

Make adjustments as necessary, referring to the above.

If you are using a hose that is 1.0(m) or longer for the hose from CVC to the dust box, adjust the CVC (SOL) suction time so that it is a fairly long time.

9. Maintenance

※The images below shows maintenance procedure for CDK-R as an example.

■Cleaning

Check chips clogging in CVC and clean it up regularly.

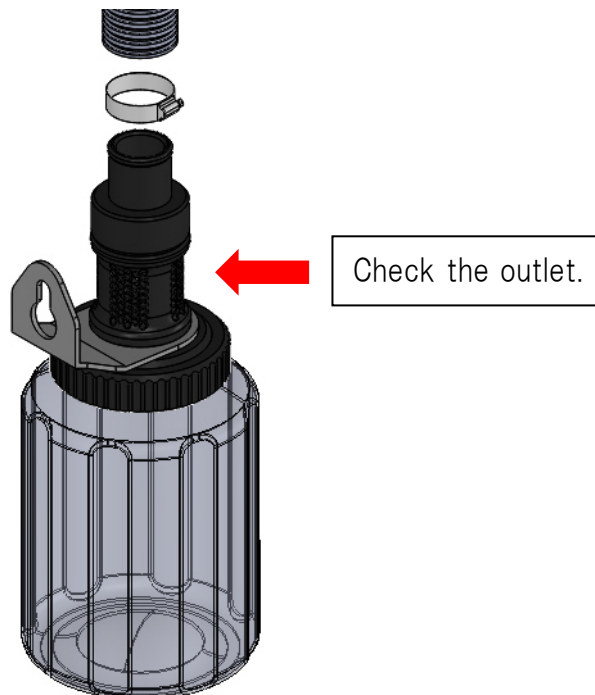
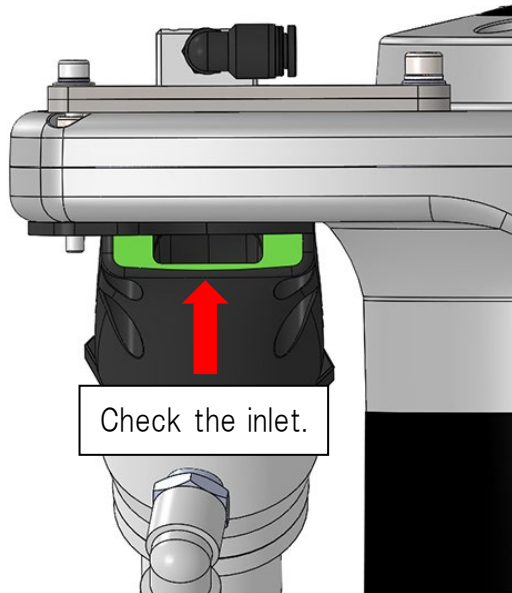

■ **Inspection**

An adapter plate is designed and made thinly to keep wide acceptance for a gun access. Check if the plate has no bent.

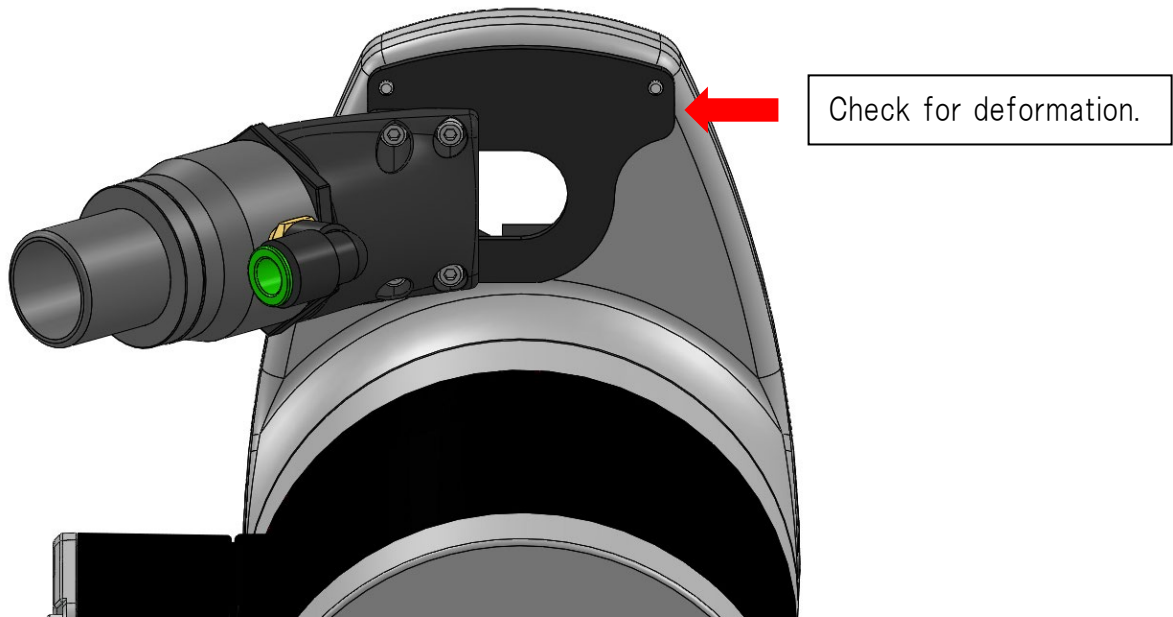

10. Troubleshooting

■ Suction is poor

1. Check the air pressure.
0.45 to 0.55MPa when the vacuum unit is in operation
0.3MPa or more when operating the optional air blow unit
Please set the equipment side so that it becomes.
2. If the discharge hose is extended, it may cause performance degradation.
3. If the hose is bent at an acute angle, the product may not be able to demonstrate its proper performance.
It may also cause a fault, so use the hose with a moderate curvature (R100 or less).
4. Furthermore, check that chips have not built up in the chip receiving section (DB-01).

11. Supplement

■ Required specs for the solenoid valve

→ One with a Cv value of 1.0 or more

■ Recommended solenoid valve type

→ SMC : VP342-5G1-02A

■ Diameter for the hose from the solenoid valve to the CVC

→ ϕ 10 or more

■ Diameter for the hose from the air source (primary side) to the solenoid valve

→ ϕ 10 or more

■ Diameter for the hose from the CVC to the dust box

→ ϕ 32 (inner dia.)

Contact

Contact us if there is any damage or machine defects in our products.



KYOKUTOH CO., LTD.

181-1, Nakayashiki, Orido-cho, Nisshin, Aichi 470-0115 Japan

TEL +81-561-72-8811 FAX +81-561-72-8821

E-Mail: sales@kyokutoh.com

<http://www.kyokutoh.com>

SAITAMA SALES OFFICE

TEL +81-49-277-4324 FAX +81-49-277-4325

HIROSHIMA SALES OFFICE

TEL +81-82-569-6227 FAX +81-82-569-6228

FUKUOKA SALES OFFICE

TEL +81-92-410-6977 FAX +81-92-410-6988



CHANGER & DRESSER CORPORATION

1527 ITC Way, Anniston, AL 36207 U.S.A

TEL +1-256-832-4392 FAX +1-256-832-4393

<http://www.changer-dresser.com>



KYOKUTOH CHINA

73 Huangang Street, Xiuquan Town, Huadu District,

GuangZhou City, GuangDong Province, China.

TEL +86-20-86980880 FAX +86-20-86980890

<http://www.kyokutoh.com.cn>



KYOKUTOH THAILAND

339/2 Soi Phattanakarn 69, Phattanakarn Road, Prawet,

Bangkok 10250 THAILAND

TEL +66-272-162-82 FAX +66-272-162-84

<http://www.kyokutoh.co.th>



KYOKUTOH KOREA

738-6 , Wonsi-dong (Byeolmang-ro 511) ,

Danwon-gu, Gyeonggi-do, KOREA 15600

TEL +82-31-414-8730 FAX +82-31-414-8731



KYOKUTOH EUROPE

Max-Planck-Str.4 59423 Unna Germany

TEL +49-2303-93-615-00 FAX +49-2303-93-615-29

<http://www.kyokutoh.de>

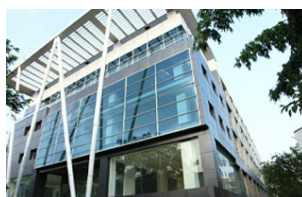

KYOKUTOH WELD INDIA

Office No.19, 3rd Floor, Aditya Centeegra, FC Road, Deccan,

Pune - 411004

TEL +91-20-68297011 FAX +91-20-68297011

