

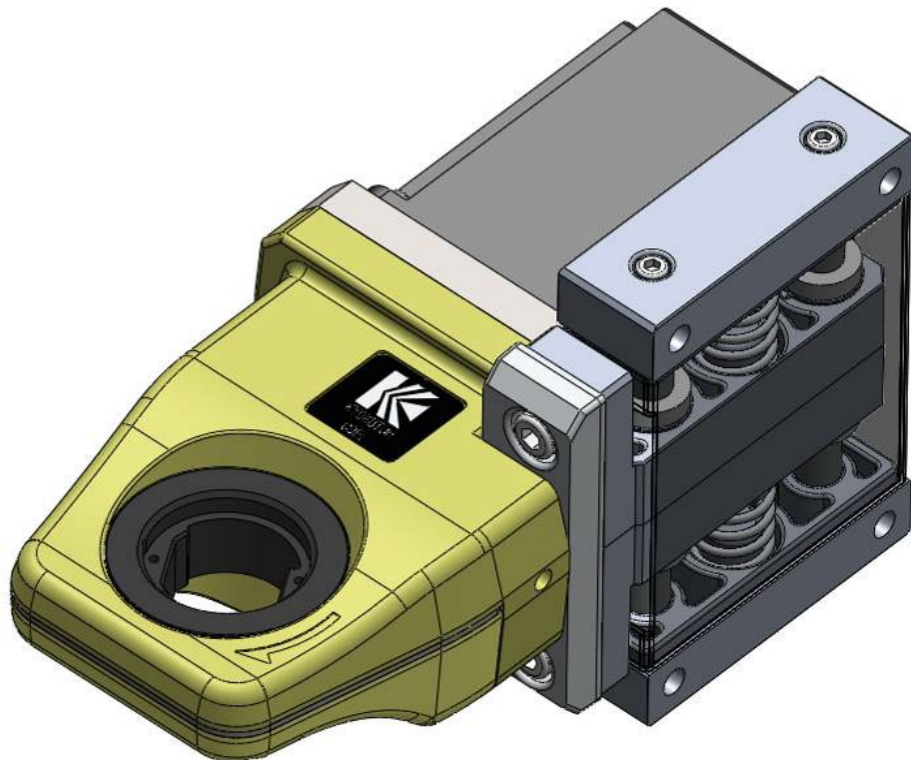

First Edition: 23.04.2020
Revised Edition: 27.10.2023

Servo Tip Dresser CDEL (SANYO motor PNP) Instruction Manual

Please read this manual before using KYOKUTOH'S High Speed Tip Dresser (CDEL)



REVISION

Revision history

Version	Date	Contents
First edition	23.04.2020	First edition issue
Revised edition	15.07.2021	Servo motor connection example postscript KANAGAWA and FUKUOKA Office postscript
Revised edition	26.08.2022	P.3 Correction
Revised Edition	27.10.2023	Installation posture correction

Cautions When Setting Up

Our miniaturized servo dresser CDEL is not designed to be set up-side down.
Please set in a proper way to avoid damage to the product.

<OK>

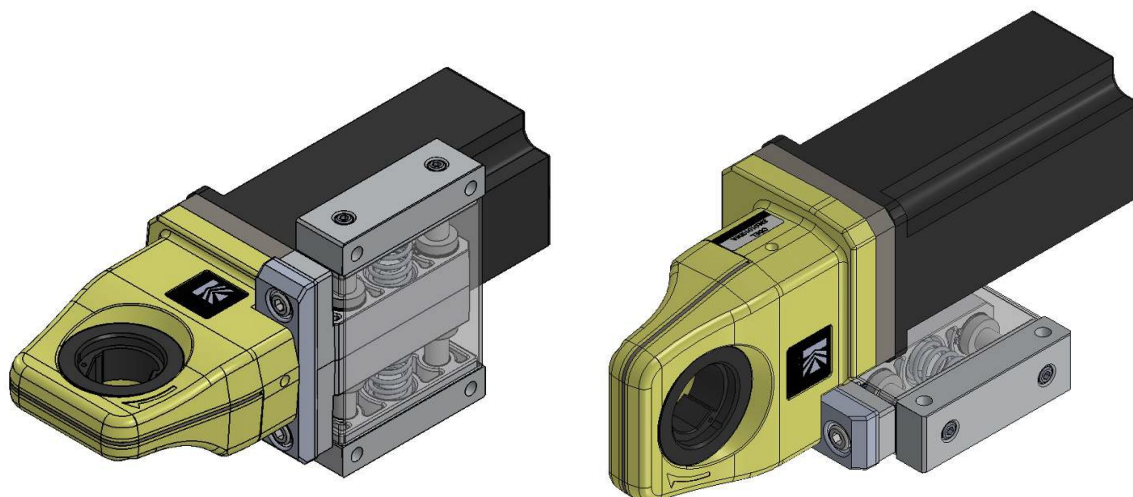

<NG>

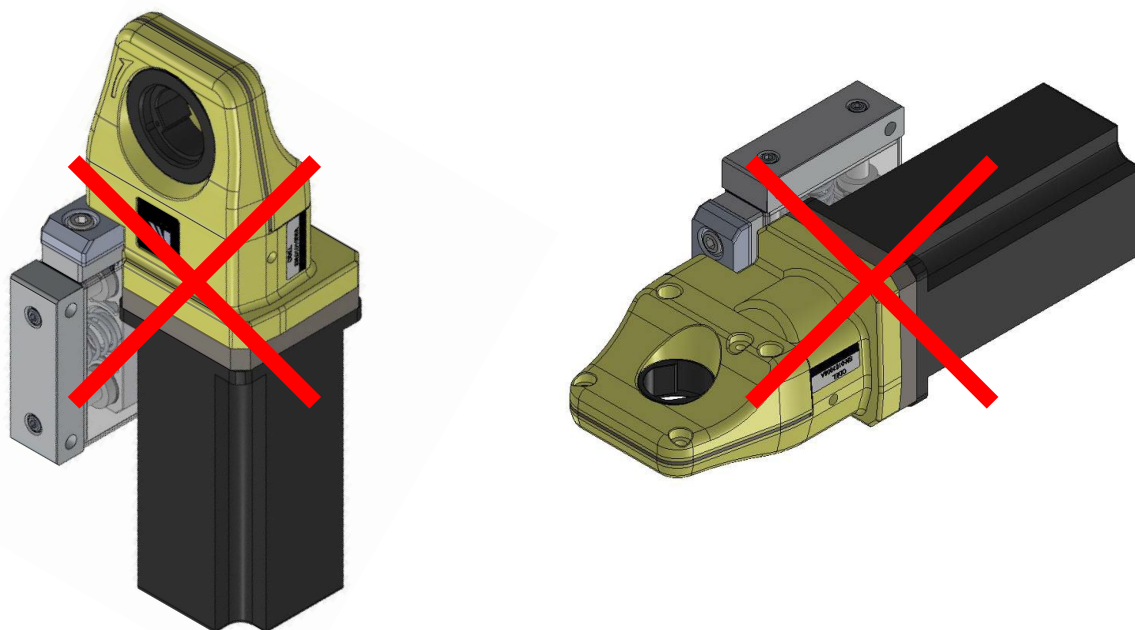



ATTENTION TO SAFETY

Please be sure to read ATTENTION TO SAFETY before using CDEL



This product is intended only for the dressing of specified electrodes. This product is not to be used in any manner other than that which is specified within. We will not be held responsible for damage or injury caused as a result of misuse of this product.

SYMBOLES

This following symbols "Warning" and "Caution", are used indicate possible hazards and to prevent their occurrence.







 Warning	Be careful to follow directions as specified, as an error could lead to possible injury or death.
 Caution	Be careful to follow direction as specified, as an error could lead to malfunction and serious damage.

The following symbols are explained below.

	This symbol indicates operations that should not be done.
	This symbol indicates operation that should be done.

※After reading, please the manual to the place where you can check the manual.

 Warning

 <p>Absolutely never disassemble or reconfigure this machine or its parts. ○ This could result in operation malfunction, ignition, or injury.</p>	 <p>Do not insert a finger or hand into gear opening while in operation. ○ This will result in serious injury.</p>
 <p>Avoid as much contact with water as possible. ○ This could result in operation malfunction (short), electrical shock or ignition.</p>	 <p>Remove the spatter, which covers the tip dresser periodically. ○ Spatter build-up can cause operation malfunction or ignition resulting in injury.</p>
 <p>Be sure to switch off the power supply, when removing or repairing wiring. ○ Will cause electrical shock.</p>	 <p>Do not use acidic or chlorine detergents for maintenance purposes. ○ Poisonous gas may be generated from the detergents, causing a possible health risk.</p>
 <p>Remove any oil that may accumulate on the tip dresser. ○ Spatter could cause ignition and possible injury.</p>	

 Caution





 <p>Firmly fix tip dresser to stand. ○ If the Tip Dresser is not fixed tightly in operation, poor dressing and other problems could occur.</p>	 <p>Be sure that the motor is not locked up. ○ This could result in overheating and possible ignition.</p>
 <p>Do not use any cutter or holder other than that which is intended and specified. ○ Use of an unspecified cutter or holder, could result in damage.</p>	 <p>Do not install near the thermal generation source of the welding machine. ○ This could cause trouble and accidents.</p>
 <p>Do not install between a welding machine and a transformer. ○ Strong magnetic forces and heat can be dangerous and possibly cause malfunctions or ignition.</p>	

TABLE OF CONTENTS

Servo Dresser Capabilities	_____	1
Servo Motor Assemble	_____	2
Criteria for Dressing Guns	_____	3
Cautions for Positioning the Dresser	_____	5
Drawing	_____	7
Parts List	_____	8
Servo motor connection example	_____	10
How to Change the Cutter	_____	11
Wiring to the Dresser	_____	13
Cutter Capacity and Dressing Time	_____	14
Timing Chart	_____	15
Cautions and Confirmation before the Operation	_____	16
How to Remove the Output Gear	_____	17
Abnormality and How to Repair	_____	19
Maintenance	_____	21
Consumption Parts List	_____	22
Contacts	_____	24

Servo Dresser Capability

	Reduction Gear Ratio	1:10
Recommended	Recommended Revolution	2500 rpm (Output revolution 250 rpm)
	Rated torque	2.4 N · m ~ 3.1 N · m
	Max torque	~ 7 N · m
Servo motor's specification	Shaft diameter of Motor	φ 16
	Shaft length from flange	40 mm
	Valid shaft length	37 mm
	Flange diameter	φ 70
	External dimension of motor	Less than □80 mm

Caution : Please set servo's torque less than 7 N · m
Please note that strong torque could break the gear.

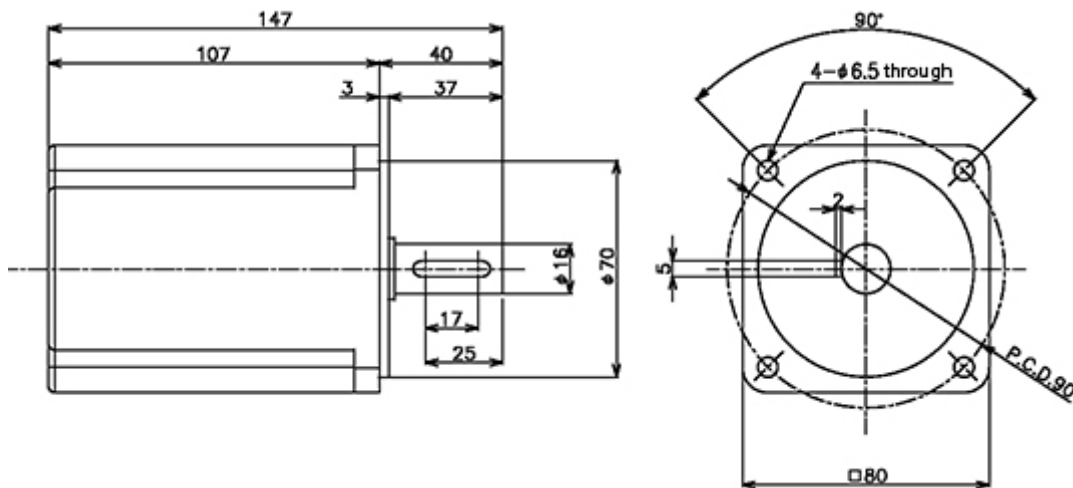

Recommended pressure is 150kgf · 1sec/ Output rotation speed 250rpm
(Motor revolution: 2,500rpm)

※Above dress time is rough indication.

Please set dressing condition flexibly based on dressed tip result after dressing.

Servo Motor Assemble

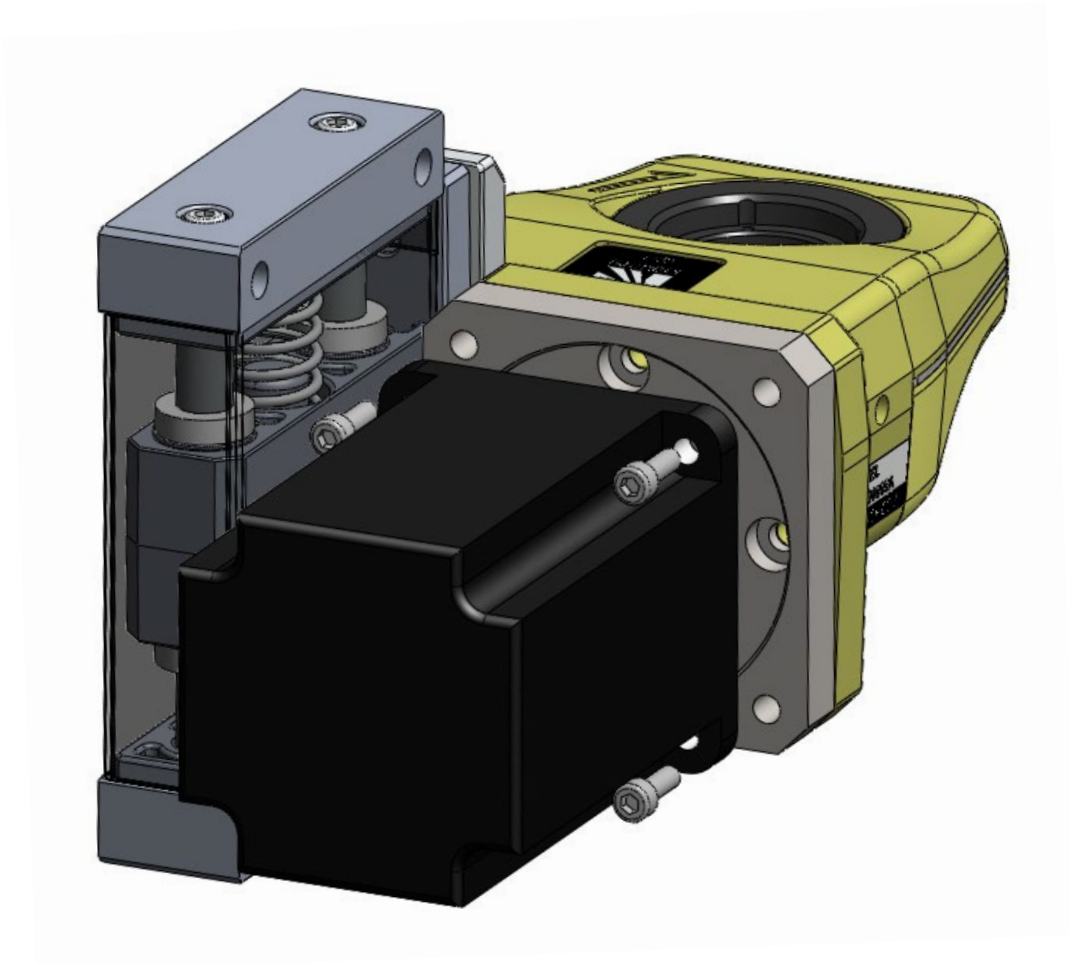

Please mount the servo motor with 4 pcs of M6 bolts after inserting the servo motor in the motor flange.

Criteria for Dressing Guns

Conditions that can be dressed

(Applicable to both X-guns and C-guns; see figure 1 and 2)

1. If A dimension is less than 30mm, this dresser is not suitable, because it may contact gearbox.
2. If B dimension is less than 48mm, this dresser is not suitable, because it may interfere with gearbox.
3. Cap tip with "C" angle up to 15 degrees can be dressed.
When using the eccentric tips or guns with angle, please contact us.
4. When the length of shank of D dimension is long, contact us for solution.
5. The base tip and insert electrode requires a particular cutter. (E dimension)
We will customize the cutter if you could provide us the gun and tip drawings.
6. Recommended dressing force is between 1,470N and 1,960N.
(Dress up to 150kgf to 200kgf)
 - When dressing pressure is less than 1,078N, there is possibility of dressing defective because of dressing amount reduction.
 - High dressing pressure from 1960N might make the dresser stop or damage the cutter and holder, depending on the shape of cap tips. In this case, please reduce the dressing pressure. If it is impossible to reduce the pressure, please contact us. We would offer you some other special cutters.
7. Select a cutter well suited to the tip shape.

Figure 1

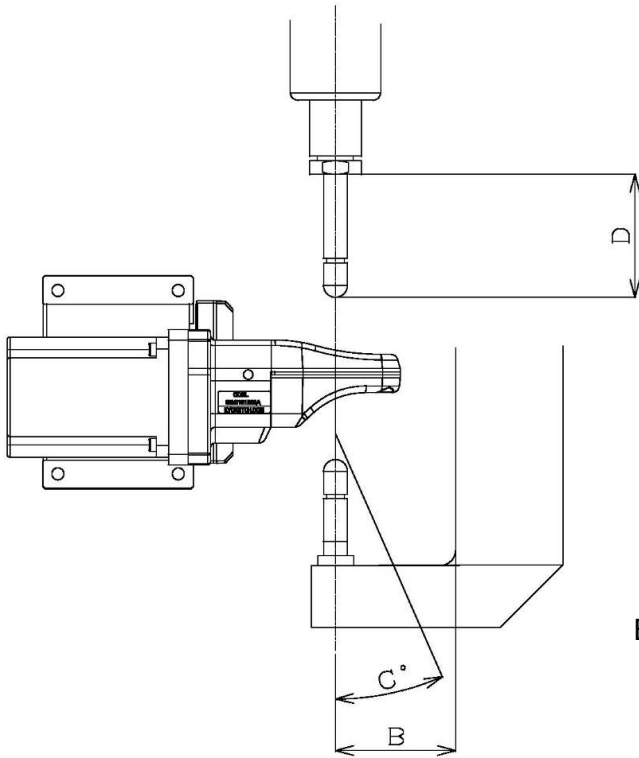

D. Concentricity guide required,
If this is over 90mm – $\phi 16$
70mm – $\phi 13$

C. Maximum 15 degrees is acceptable.

B. To avoid interference with gearbox, 40mm.

Figure 2

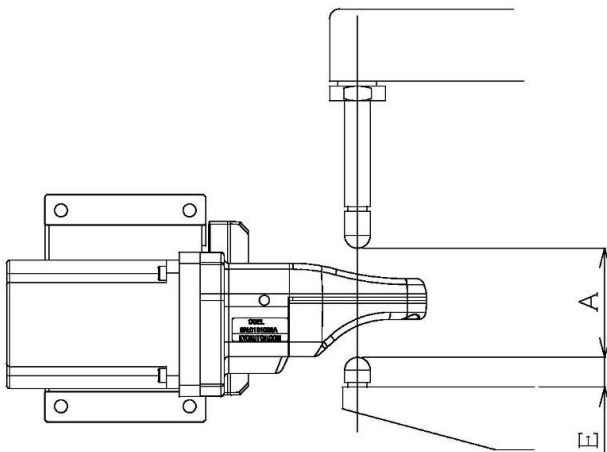

A. Tip opening needs over 25mm.

E. The special cutter should be used
for the shorter tips.

Cautions for Positioning the Dresser

ATTENTION

1. The tip should be set parallel to floating mechanism. (See figure 3)
2. For X-guns, set the dressing location to the pressurization location. (See figure 4)
3. For C-guns, set the dressing location even level with pressurization location, otherwise it might cause poor dressing or damage gears and bearings.
4. Although the floating mechanism is installed in dresser, we also recommend that you locate the dressing position as closely as possible.
5. Dressing horizontally C-Guns vertically set with equalizing mechanism is difficult to keep weight balance of springs, and pressurization point could easily change. So in this case, please make sure of pressurization point very well when you teach robots. (See figure 4 and 5)

Figure 3

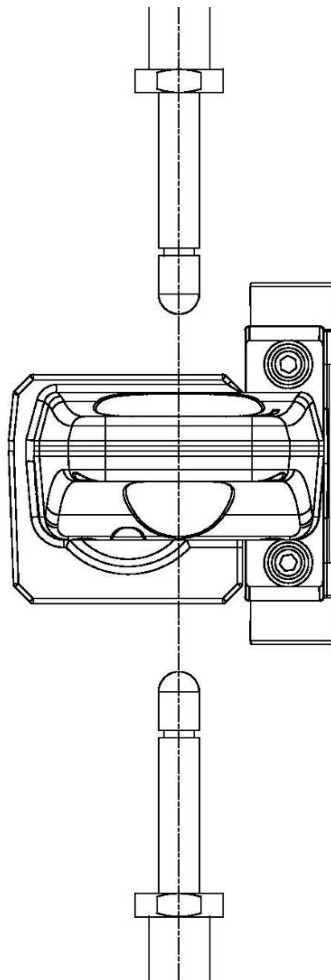

Figure 4

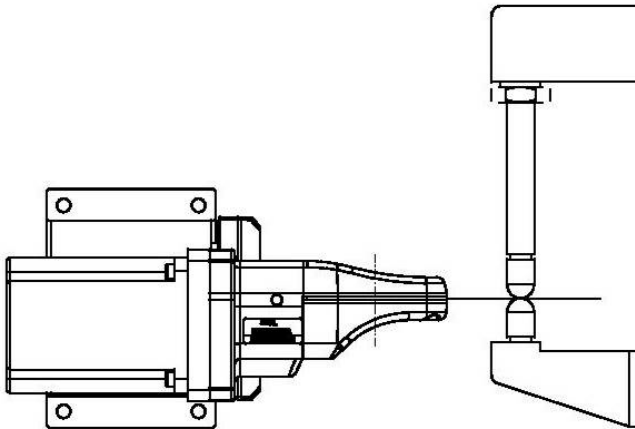
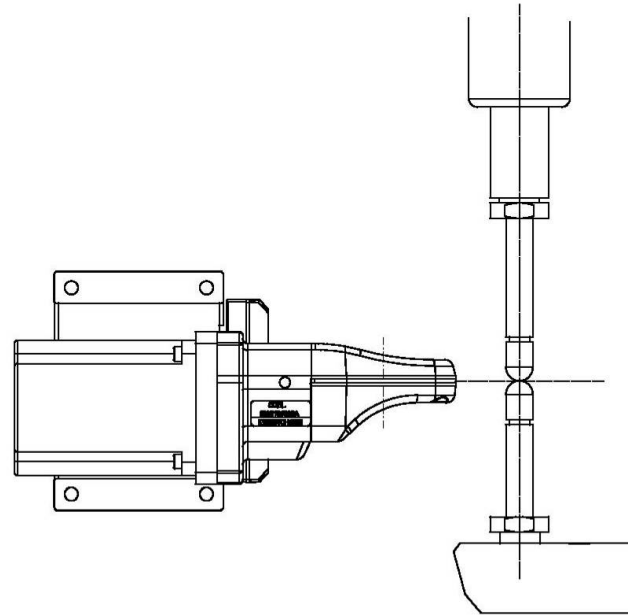
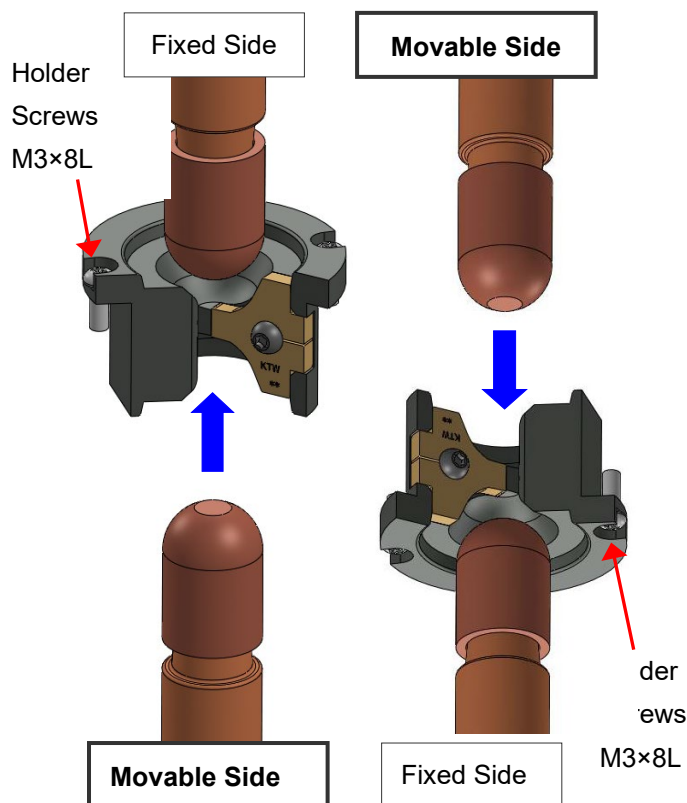

Figure 5



"ATTENTION" for dress teaching

< Picture 1 > **(Incorrect)**



< Picture 2 > **(Correct)**

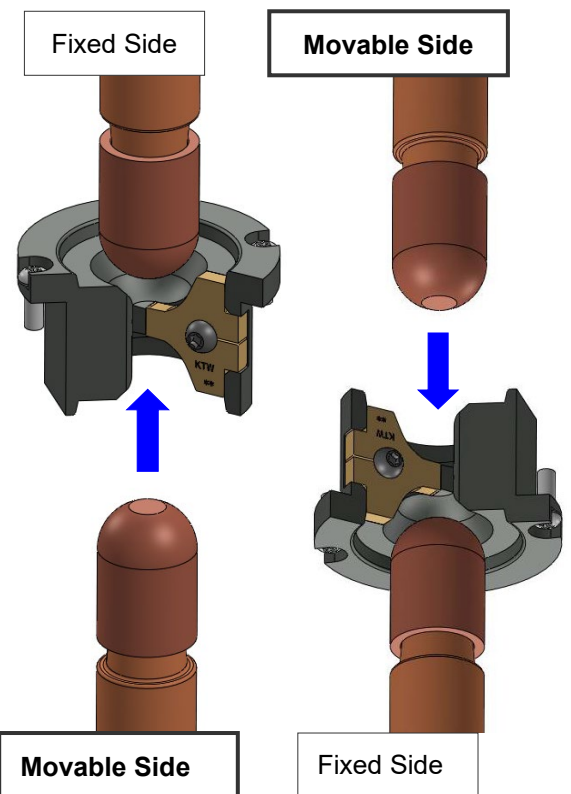

※Please don't make room between a cap on a fixed side and a cutter blade as picture 1 shows. It would cause screw heads broken off and a holder fallen off once the holder is pushed up or pushed down from the bottom side of the holder. Please have a cap touch on a cutter blade as a picture 2 shows for a proper dress teaching.

Drawing

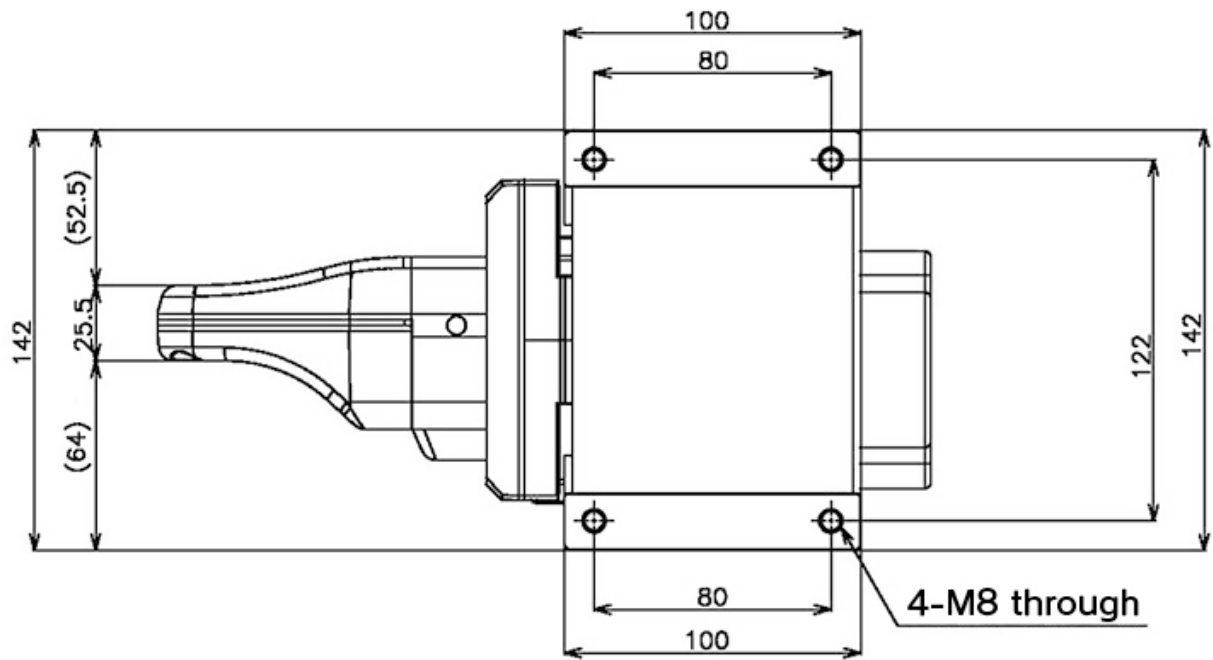
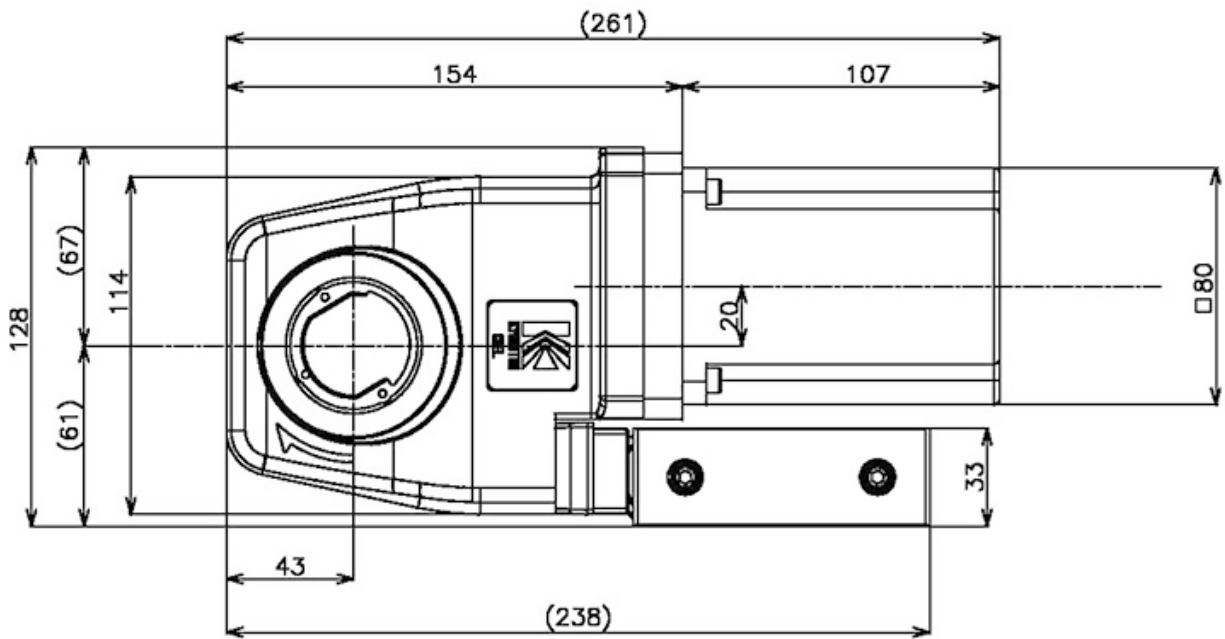

4-M8 Recommended tightening torque : 18N · m

Parts List

MAIN BODY

NO.	Parts Name	Type or Size	QTY
1	Tip Dresser	CDEL	1
2	Output Gear	CDEX-R75-01-05B	1
3	Output Bearing	NTN 6811LLB	1
4	Input Gear	CDEX-R750-01-10B-16	1
5	Input Bearing	NTN 60/28LLB	2
6	Floating Unit	ELFLU-15-02	1
7	Servo Motor	R2AA08075FXH11M	1

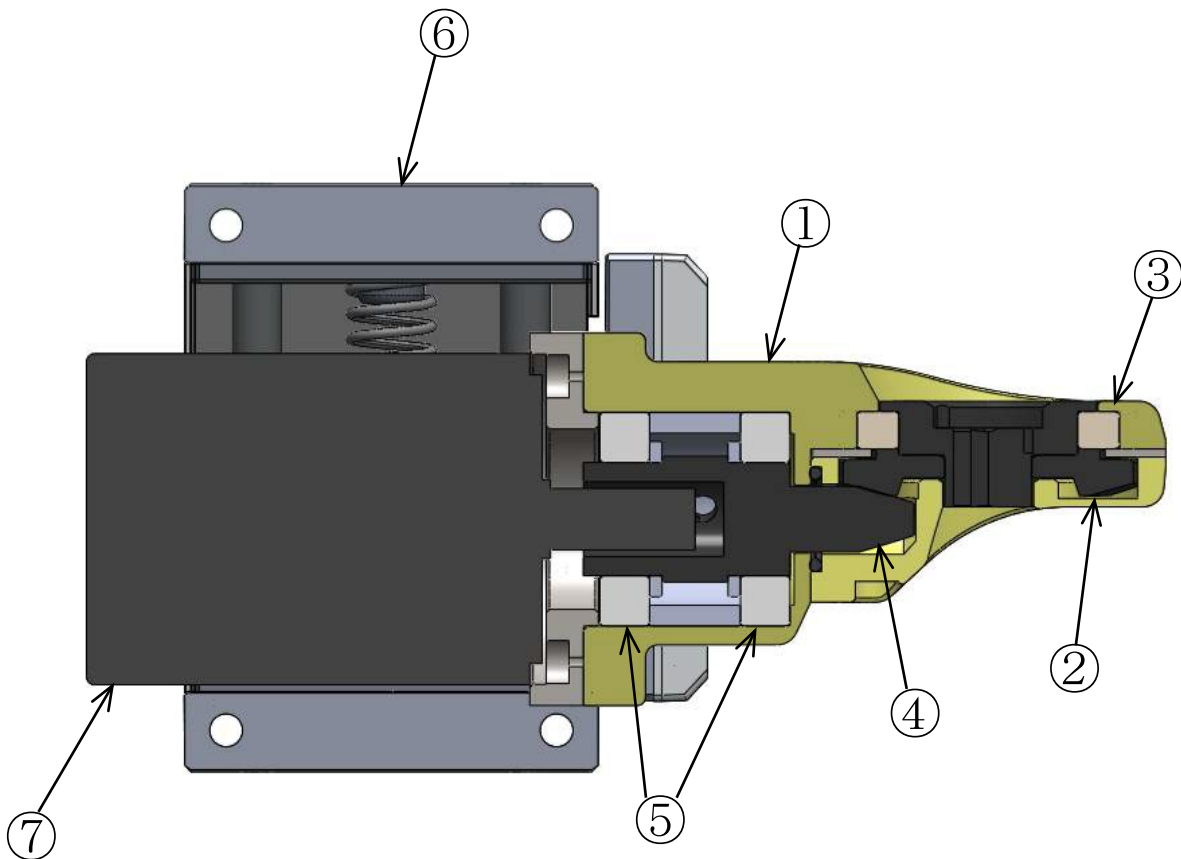

FLOATING UNIT

NO.	Parts Name	Type or Size	QTY
1	Floating Block	FLU-15-01-002	1
2	Floating Plate	FLU-15-01-003	2
3	Special Slide shaft	FLU-15-01-005	2
4	Slide Cover	FLU-15-01-006	1
5	Samini Spring	11-2253	2
6	C Ring	STW-21	4
7	Slide Bearing	Y-12LUU	2
8	SUS Cap Bolt	M5 × 20	4
9	SUS Cap Bolt	M8 × 15	2
10	Dowel Pin	φ5h7-30L	2

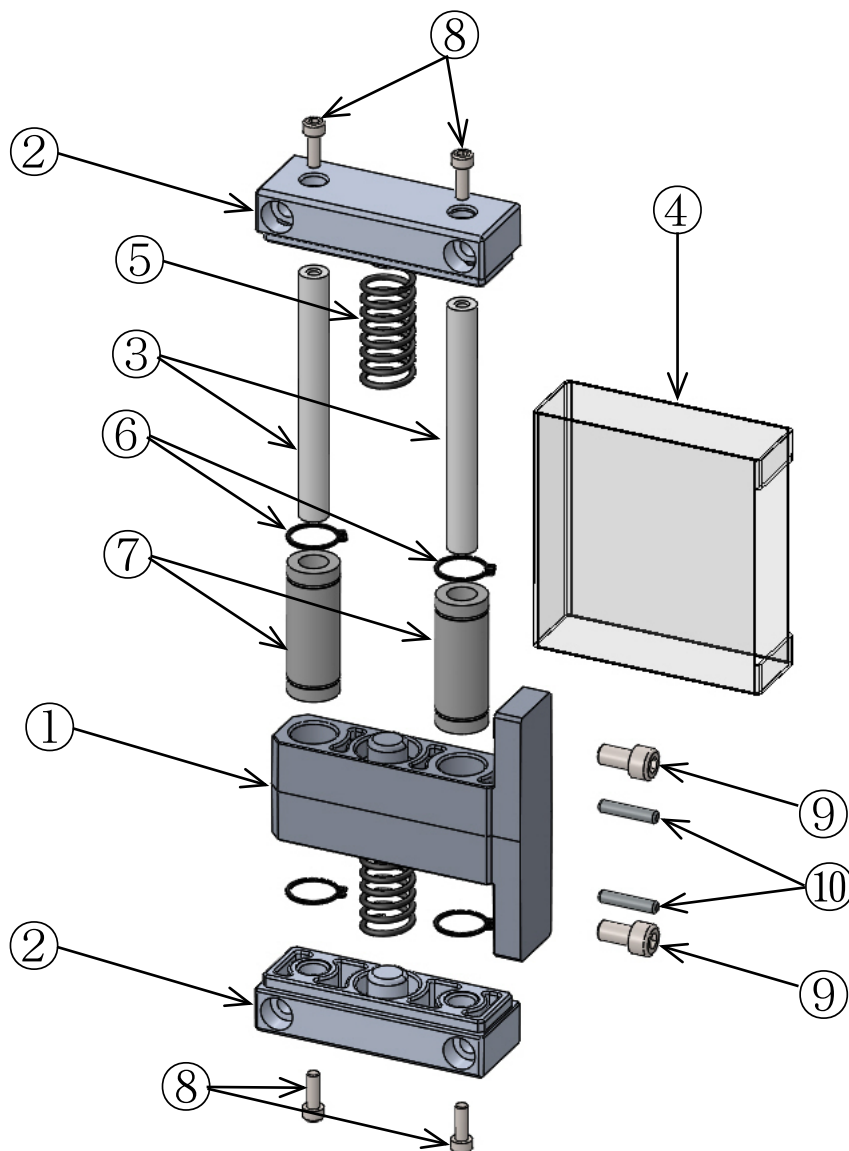

Servo motor connection example

NO.	Parts Name	Type or Size	QTY	Note
1	Servo Motor	R2AA08075FXH11M	1	
2	Amplifier	RS2A03A0BA0	1	NPN
3	Power Cable for Motor		1	1m
4	Encoder Cable		1	1m
5	Harness	SHPM-HAT-SB-50-0.5	1	

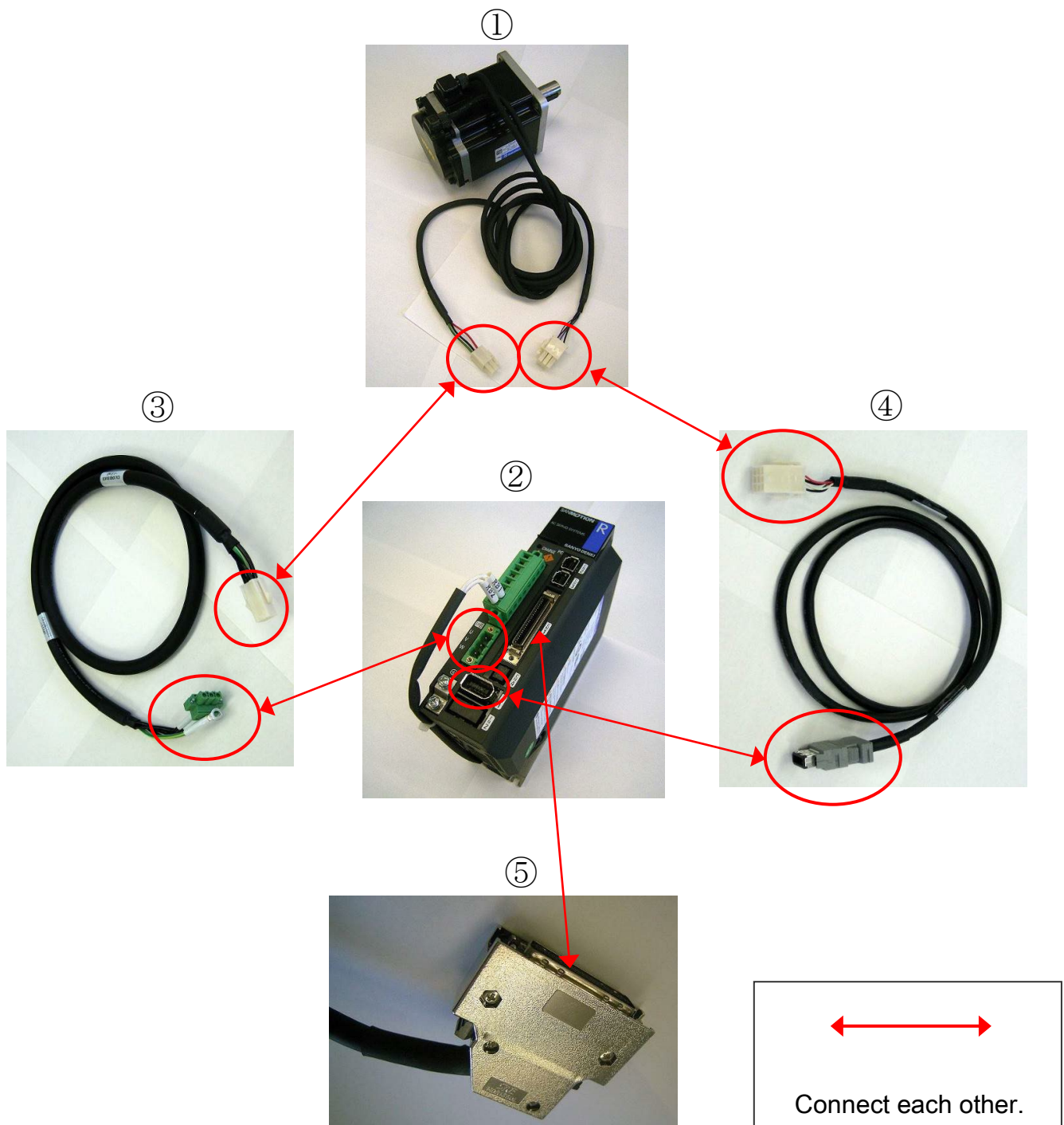

How to Change the Cutter

1. Remove M3 screws from the cutter holder.
※Recommended torque for M3 screw is to 0.95N · m

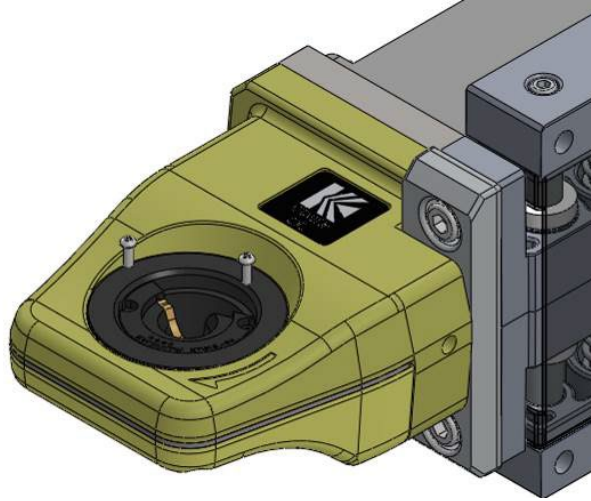

2. Remove the cutter holder from the dresser.

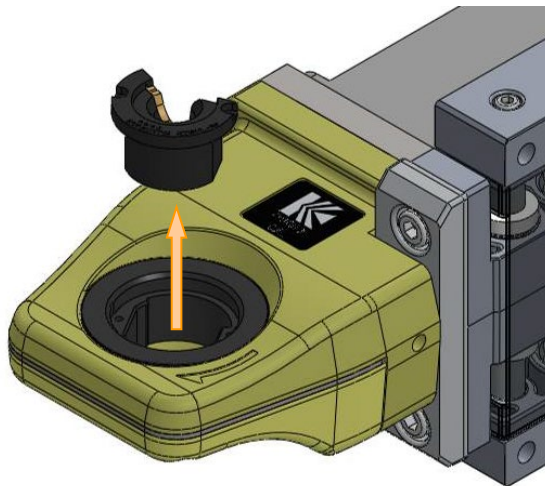

3. To remove the cutter from the cutter holder, loosen the M3 torque screw.
(With a torque wrench T-10)



4. Replace a new cutter

Confirm cutter is replaced in the proper direction.

Please install the angle narrow on the side where touches the holder.

✘Inscription faced up

(Recommended torque for M3 screw is to 1.0~1.2N · m).

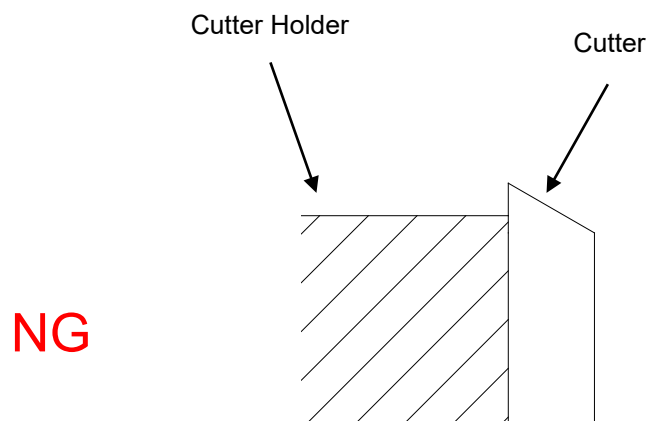
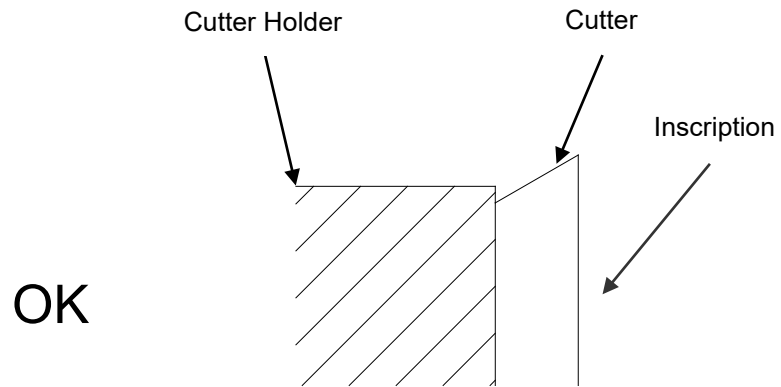

5. To install the cutter holder to the dresser, please do the reverse order from 1 to 2.

Wiring to the Dresser

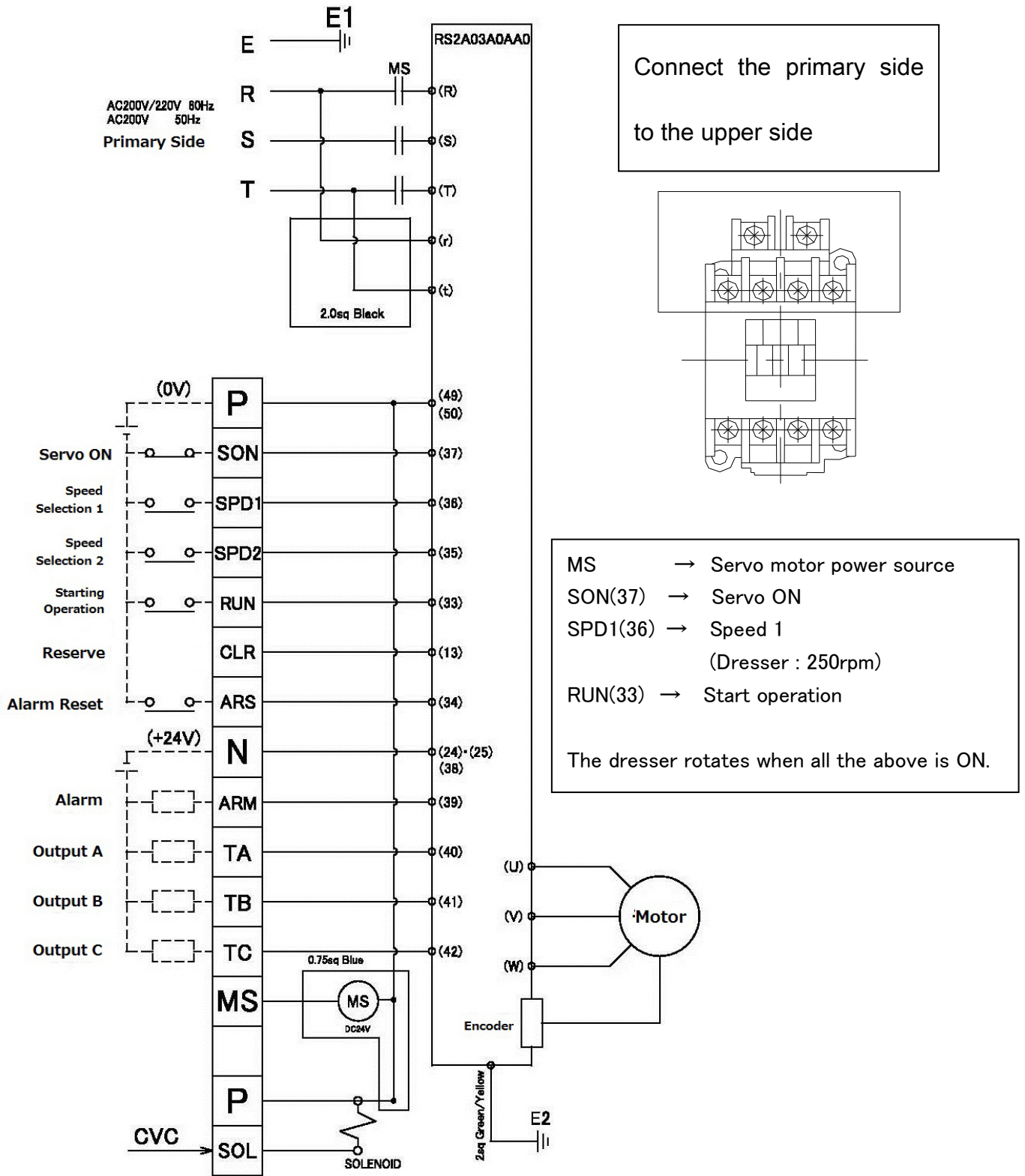

Note) Connect the Earth wire to cover side.

※Control Box is not included in the dresser.

Cutter Capacity and Dressing Time

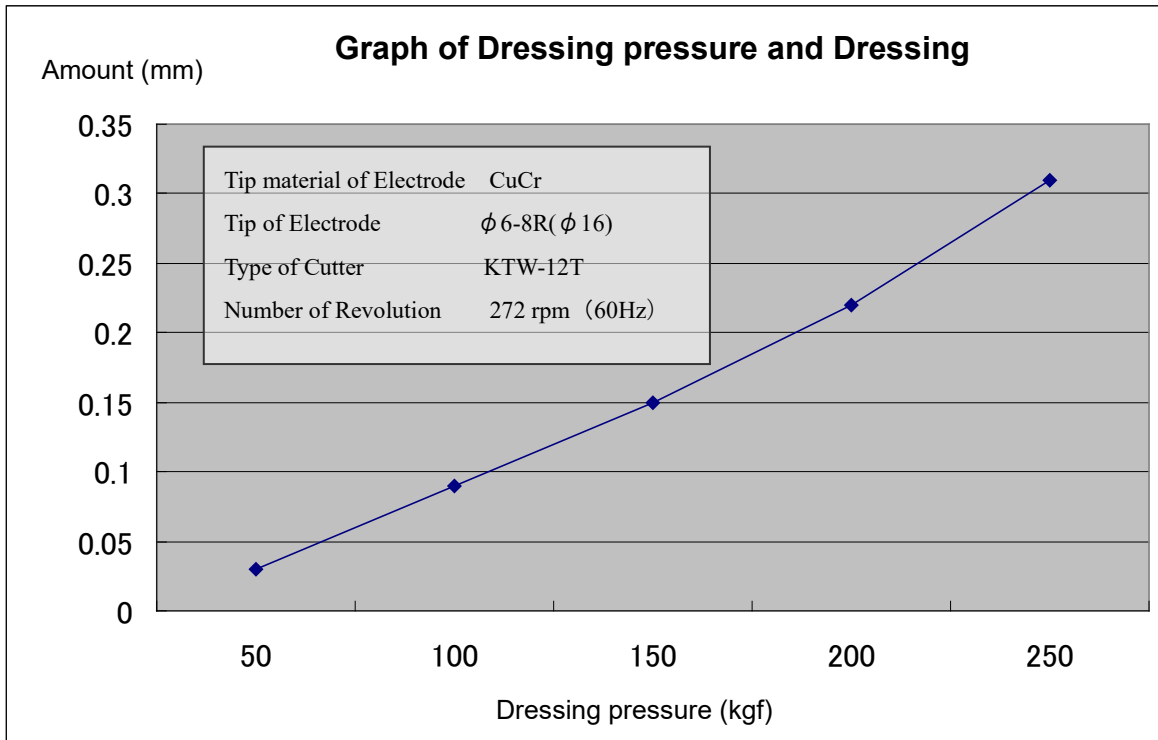

Estimated Dressing Time

Dressing time: 1 sec

Please adjust dressing time and pressure according to above graph.

- Example 1: to dress 0.1mm
 - Dressing time: 1 sec
 - Dressing pressure: 110kgf
- Example 2: to dress 0.1mm
 - Dressing time: 0.7 sec
 - Dressing pressure: 150 kgf

Above examples are rough indications for the default. If you find cap tips are dressed not enough or too much while using, please adjust the setting to your cap tips.

● Average dressing cycle of KTW cutters after 200 welds is 1 to 2 seconds.

ATTENTION

It might cause a chip clogging if a dressing time is more than 1 sec. If dressing time is required more than 1 sec, it is recommended to be dressed multiple times to avoid chip clogging.

For example: If need 2 sec dressing time → 1 sec x 2 times dressing

We have various types of cutters with different shapes and different metallic finishing for optimum dressing. So even if you changed the length of dressing time or the amount of dressing pressure and still couldn't get better result, please contact us.

Timing Chart

KTW type Cutter (Only clockwise rotation)

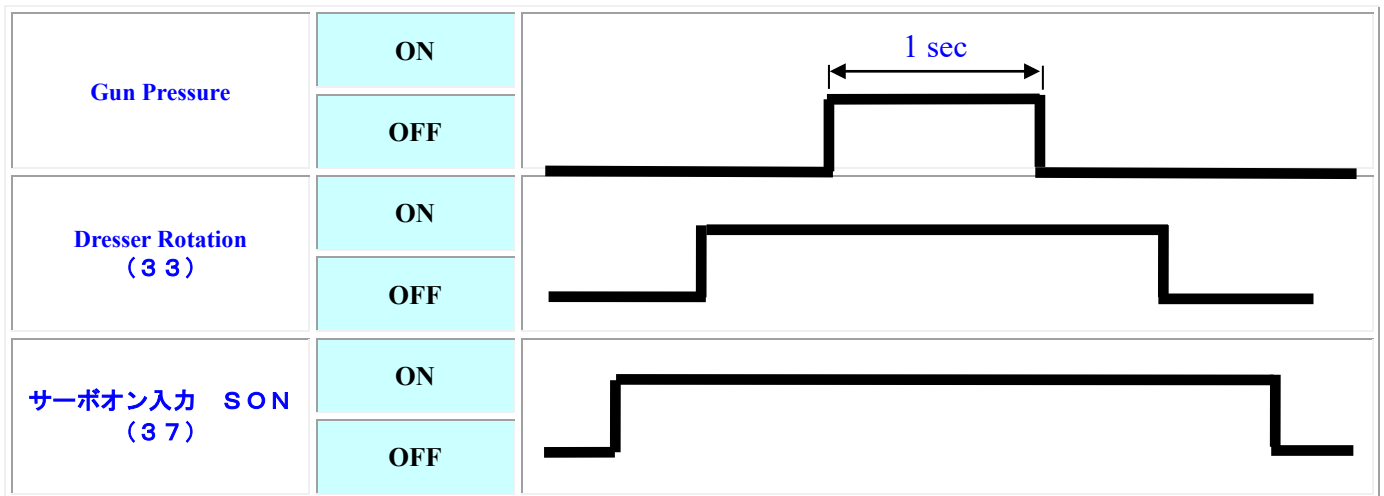

- SPD1 (36) → Rotation speed setting of the dresser.
- RUN (33) → Start rotation. (The dresser will keep rotating while the signal is "ON".)
- SON (37) → Servo ON. (The dresser will NOT response to any signals unless "Servo ON" is applied.)
- ARS (34) → Clear Alarm.
- ARM (39) → Alarm Output.

- ① Start motor to clockwise before Gun press.
- ② Set the dressing time according to your tip condition. Approximately **MAX 1sec.**
"ATTENTION"
 It might cause a chip clogging if a dressing time is more than 1 sec. If dressing time is required more than 1 sec, it is recommended to be dressed multiple times to avoid chip clogging.
 For example: If need 2 sec dressing time → 1 sec x 2 times dressing
- ③ Confirm rotate direction (clockwise).
- ④ To finish dressing, release the gun pressure while dresser is revolving.

Before operating, make sure that the forms of cutter and tip are fitting.
 When dressing is finished and small scrapes are left on the cap tips, both upper and lower tips should be touched with the cutter of revolving dresser before returning to original position.

Cautions and Confirmation before the Operation

1. Confirm the specification again. (Voltage, option, etc)
 2. Make sure of the conformity between the forms of cutter and cap tips.
 3. Install the dresser in the place where the operator can not touch it directly during the operation.
 4. Make sure dresser and stand bolts are tightened firmly. Also, confirm stand is fixed securely to the floor.
 5. When connecting wires to the dresser, operation procedures must be followed with the electric construction standard and also make sure that it is protected from cooling water and spatter.
 6. Be certain dresser is grounded.
 7. Make sure dresser is installed in a location with no spatter and cooling water directly.
 8. Confirm the forms of the cutter and cap tips once again before robot teaching, Confirm that cutter and holder are securely fastened.
 9. Confirm the rotation direction of the KTW cutter is clockwise.
 10. Make sure there is neither interference to the dresser except for the cap tips, nor any allophone when robot teaching.
 11. When the gun is pressurized, make sure that the electric current is not applied and pressure is within the setting range.
 12. Confirm the quality of the dressed tip. Be sure that the shank is stable and not shaking during dressing.
- ◆The causes of the failure in dressing.
- The gun is not released while the dresser is revolving. (Scrapes are left on the cap tips)
 - The pressure is too high or too low.
 - The forms of the cap tip and the cutter are not fitting.
 - The dressing time is too short.
 - The teaching point differs from the dressing one.
 - The shape of used cap tips differs from new ones too much.
- ◇If the cap tips can't get dressed properly with any other reason, please contact us.

How to Remove the Output Gear

1. Remove M6 cap bolts from the servo motor.

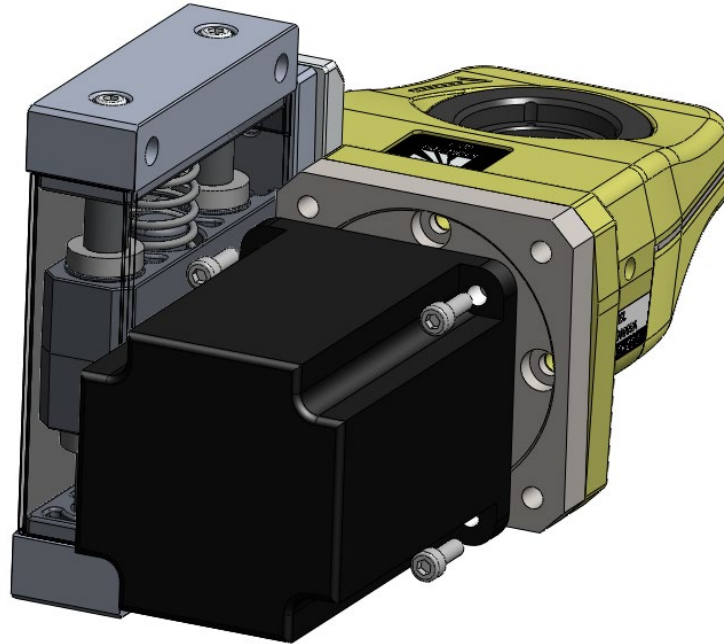

2. Remove the motor flange.

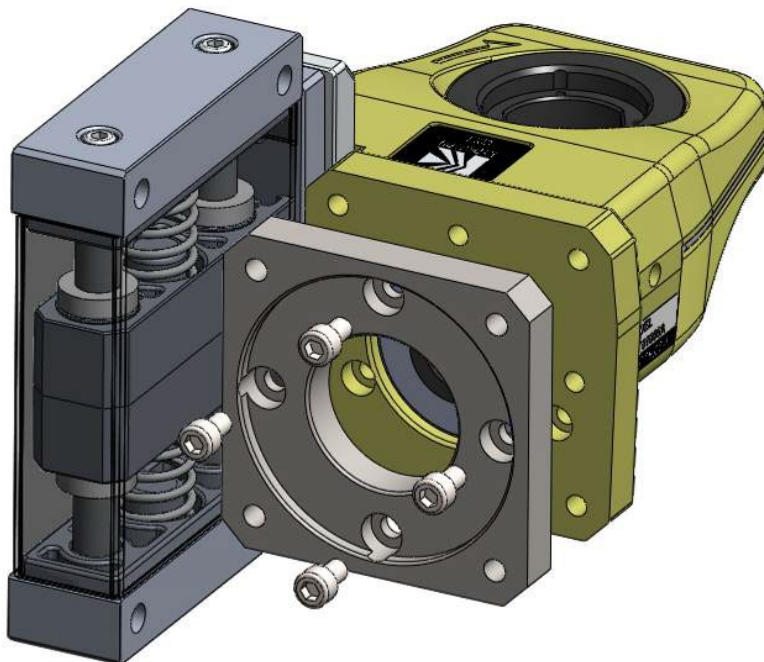

3. Remove the motor flange.

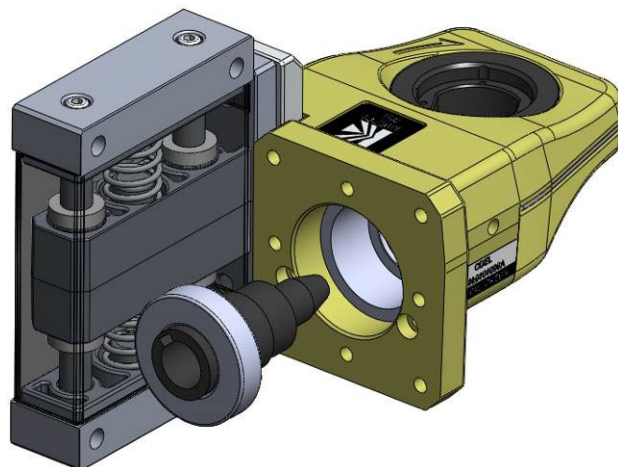

4. Remove the lower gearbox.



5. Remove the Output gear.



Abnormality and How to Repair

Abnormal Condition	Cause and Countermeasure
Dresser does not rotate.	<ul style="list-style-type: none"> * Servo motor is not rotating →Check the power source. * The gun pressure is higher than specified by our company. →Set gun pressure under 1960N(200kgf). * The shapes of the cutter and the cap tip are not fitting, and cling each other. →Check the cutter shape and replace it if necessary.
The motor is running but the cutter does not rotate.	<ul style="list-style-type: none"> * Gear in the gear box is broken. →Need repair to replace the gear.
The diameter of the dressed cap tip is different from the setting.	<ul style="list-style-type: none"> * Dressing time is too short. →Set the dressing time to the tip that has been crushed most. * The cutting capability of the cutter has deteriorated or the cutter has been damaged. →Replace the cutter and check the gun pressure. * Dressing point is not proper. →Re-do teaching. * The cutter is not suitable for the cap tip. →Check the cutter shape and replace it if necessary. * Gear in the gear box is broken. →Need repair to replace the gear. * The screw which fastens the cutter to the holder is loosen. →Tighten the screw.
Abnormal sound during dressing.	<ul style="list-style-type: none"> * Dressing point is not proper. →Re-do teaching. * The cutter has been damaged. →Replace the cutter and check the gun pressure.

Abnormal Condition	Cause and Countermeasure
Dresser leaves burr on the cap tip.	<ul style="list-style-type: none"> * The control method is not proper. →Release the gun while dresser is revolving, and then stop the dresser. * The shapes of the cutter and the cap tips are not fitting. →Check the cutter shape and replace it, if necessary. * The cutter has been damaged. →Replace the cutter and check the gun pressure. * The screw which fastens the cutter to the holder is loosen. →Tighten the screw.
The tip diameter is not at the center or the designated location.	<ul style="list-style-type: none"> * The cap tip has got too short. →Replace the cap tip to new one. * Dressing position is not proper. →Re-do teaching.
The point of the cap tip is an oval, not a circle	<ul style="list-style-type: none"> * The bolts that fasten the motor and the gear box are loosen. →Tighten the bolts. * The bolts that fasten the dresser to the stand are loosen. →Tighten the bolts
Dressing does not complete in the set time	<ul style="list-style-type: none"> * Dressing time is too short. →Set the dressing time to the cap tip that has been crushed most. * The cutting capability of the cutter has deteriorated or the cutter has been damaged. →Replace the cutter and check the gun pressure. * The cap tip is soften after welding, the point of the cap tip gets widened. →Increase the dressing pressure gradually according to the time of dressing a cap tip when it is with gun voltage valve.
<p><Remarks></p> <ul style="list-style-type: none"> ◆ Please be sure the switch is off when you are checking or replacing parts or the cutter. ◆ When the dresser is out of order, please contact us immediately. Do not take the dresser apart. It would not be able to repair if you disassemble it. 	

Maintenance

※Lubricate once a year with 10 g for each.

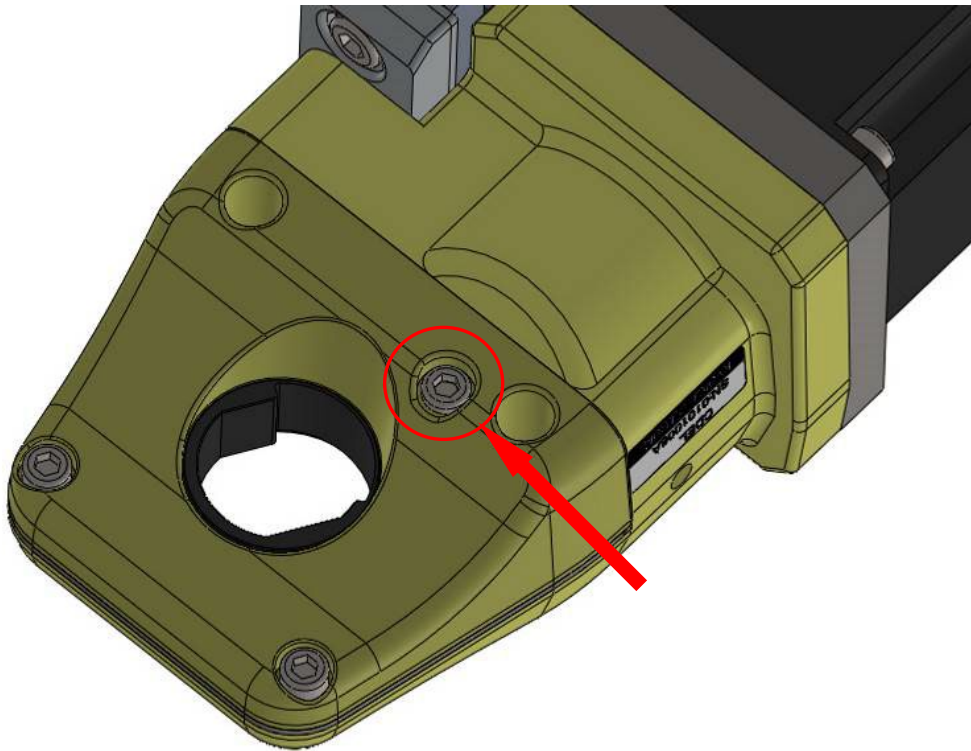

Remove the M6 Cap bolt.



Install grease nipple(M6*P=1.0).

Supply the greased with grease gun.

Grease: Water-resistant industrial grease, NLGI No.1

(that has excellent anti-corrosion and water resistance, which is suitable to be used in wet and damp environments.)

Consumption Parts List

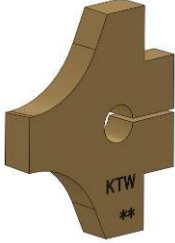
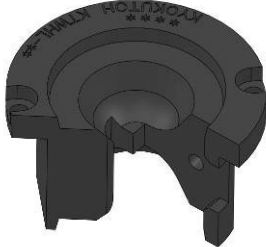
<div style="border: 1px solid black; padding: 10px; display: inline-block;"> <p style="font-size: 1.2em; margin: 0;">Outsourced Product</p> </div>	<p>Output Gear Bearing for KTW Type:NTN 6811LLB Replacement Qty:1pcs Replacement cycle:2years</p> <p>Input Gear Bearing for KTW Type:NTN 7205 Replacement Qty:2pcs Replacement cycle:2years</p>
	<p>Input Gear for KTWEXH holder Type:CDEX-R750-01-10B-16 Replacement Qty:1pcs Replacement cycle:2years</p>
	<p>Output Gear KTWEXH holder Type:CDEX-R750-01-05B (With Ring stopper CDEX-R750-01-04B) Replacement Qty:1pcs Replacement cycle:2years</p>
	<p>Cutter Type:KTW-** Replacement Qty:1pcs Replacement cycle:10,000 sec</p>
	<p>Cutter Holder Type:KTWHL-** Replacement Qty:1pcs Replacement cycle:30,000 sec</p>

MEMO

Contacts

Contact us if there is any damage or machine defects in our products.



KYOKUTOH CO., LTD.

181-1, Nakayashiki, Orido-cho, Nisshin, Aichi 470-0115 Japan

TEL +81-561-72-8811 FAX +81-561-72-8821

E-Mail: sales@kyokutoh.com

<http://www.kyokutoh.com>

SAITAMA SALES OFFICE

TEL +81-49-277-4324 FAX +81-49-277-4325

HIROSHIMA SALES OFFICE

TEL +81-82-569-6227 FAX +81-82-569-6228

FUKUOKA SALES OFFICE

TEL +81-92-410-6977 FAX +81-92-410-6988



CHANGER & DRESSER CORPORATION

1527 ITC Way, Anniston, AL 36207 U.S.A

TEL +1-256-832-4392 FAX +1-256-832-4393

<http://www.changer-dresser.com>



KYOKUTOH CHINA

73 Huagang Street, Xiuquan Town, Huadu District,
GuangZhou City, GuangDong Province, China.

TEL +86-20-86980880 FAX +86-20-86980890

<http://www.kyokutoh.com.cn>



KYOKUTOH THAILAND

339/2 Soi Phattanakarn 69, Phattanakarn Road, Prawet, Bangkok
10250 THAILAND

TEL +66-272-162-82 FAX +66-272-162-84

<http://www.kyokutoh.co.th>



KYOKUTOH KOREA

738-6 , Wonsi-dong (Byeolmang-ro 511) ,

Danwon-gu, Gyeonggi-do, KOREA 15600

TEL +82-31-414-8730 FAX +82-31-414-8731



KYOKUTOH EUROPE

Max-Planck-Str.4 59423 Unna Germany

TEL +49-2303-93-615-00 FAX +49-2303-93-615-29

<http://www.kyokutoh.de>



KYOKUTOH WELD INDIA

Office No.19, 3rd Floor, Aditya Centeegra, FC Road, Deccan,
Pune - 411004

TEL +91-20-68297011 FAX +91-20-68297011

